

Graphs

Introduction

- Generalization of a tree.
- Collection of vertices (or nodes) and connections between them.
- No restriction on
 - The number of vertices.
 - The number of connections between the two vertices.
- Have several real life applications.

Definition

- A graph $G = (V, E)$ consists of a
 - Non-empty set V of *vertices* and
 - Possibly empty set E of *edges*.
- $|V|$ denotes number of vertices.
- $|E|$ denotes number of edges.
- An edge (or arc) is a pair of vertices (v_i, v_j) from V .
 - Simple or undirected graph $(v_i, v_j) = (v_j, v_i)$.
 - Digraph or directed graph $(v_i, v_j) \neq (v_j, v_i)$.
- An edge has an associated **weight** or **cost** as well.

Contd...

Undirected Graph

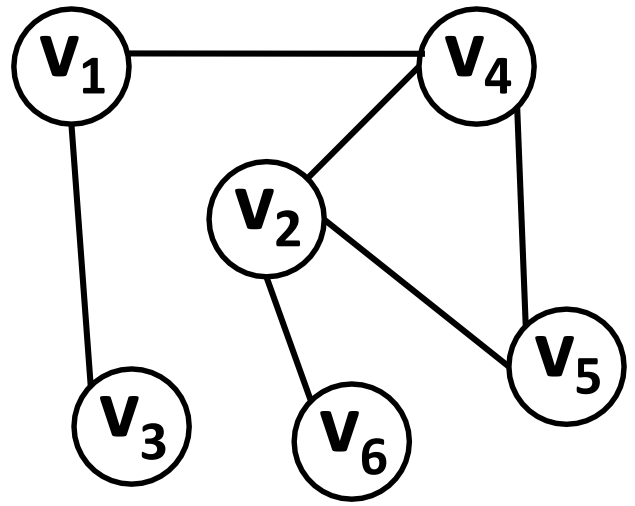

Directed Graph

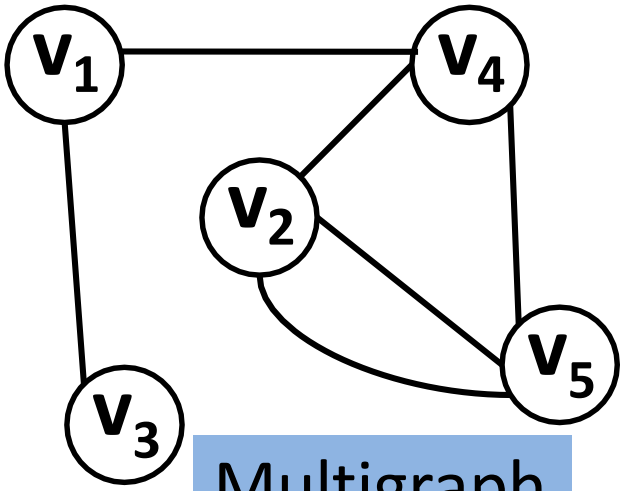
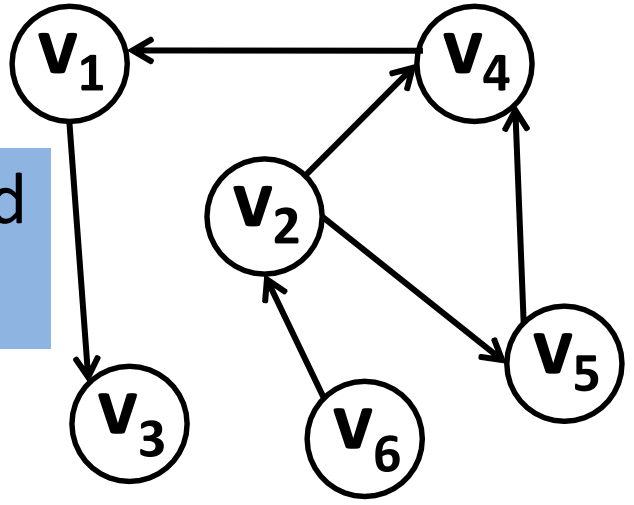

Multigraph

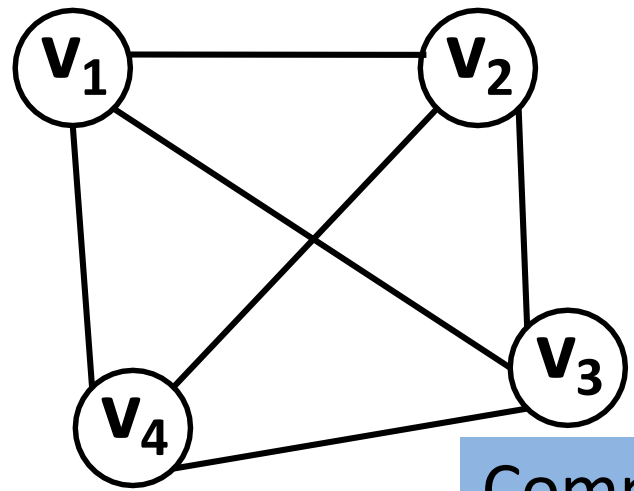

Complete Graph

Representation – I

- Adjacency matrix
 - Adjacency matrix for a graph $G = (V, E)$ is a two dimensional matrix of size $|V| \times |V|$ such that each entry of this matrix
$$a[i][j] = \begin{cases} 1 \text{ (or weight), if an edge } (v_i, v_j) \text{ exists.} \\ 0, \text{ otherwise.} \end{cases}$$
 - For an undirected graph, it is always a symmetric matrix, as $(v_i, v_j) = (v_j, v_i)$.

Adjacency matrix

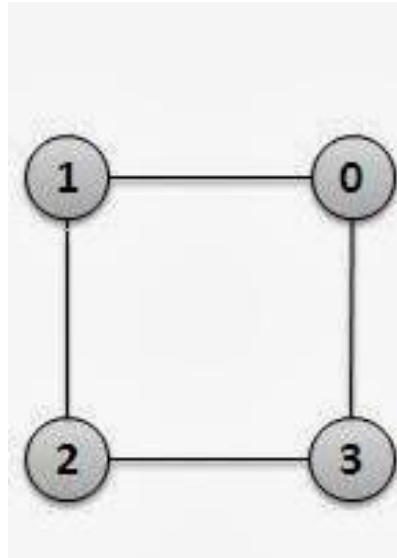

	0	1	2	3
0	0	1	0	1
1	1	0	1	0
2	0	1	0	1
3	1	0	1	0

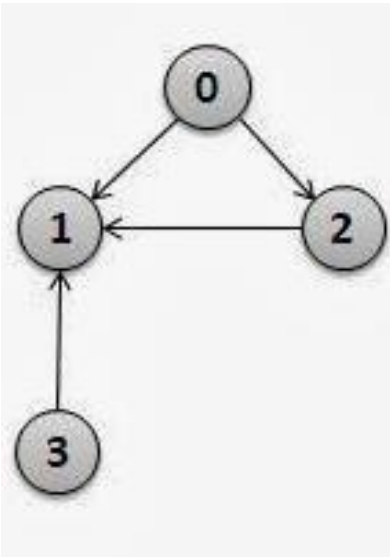

	0	1	2	3
0	0	1	1	0
1	0	0	0	0
2	0	1	0	0
3	0	1	0	0

Contd... (weighted)

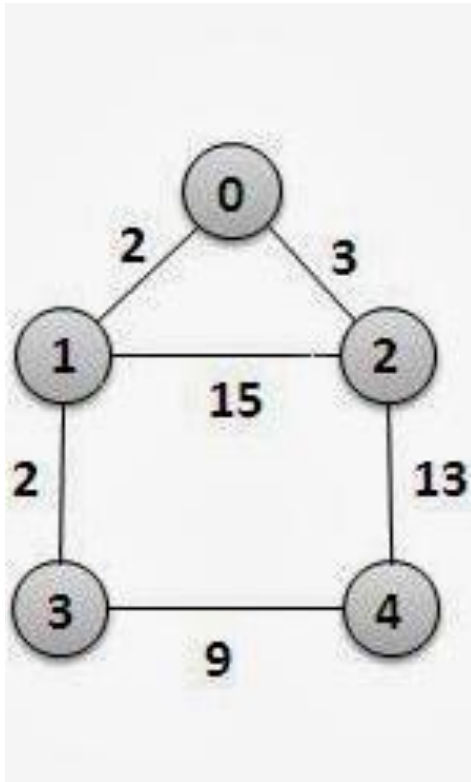

	0	1	2	3	4
0	0	2	3	0	0
1	2	0	15	2	0
2	3	15	0	0	13
3	0	2	0	0	9
4	0	0	13	9	0

Representation – II

- Adjacency list
 - Uses an array of linked lists with size equals to $|V|$.
 - An i^{th} entry of an array points to a linked list of vertices adjacent to v_i .
 - The weights of edges are stored in nodes of linked lists to represent a weighted graph.

Adjacency List

- Undirected graph

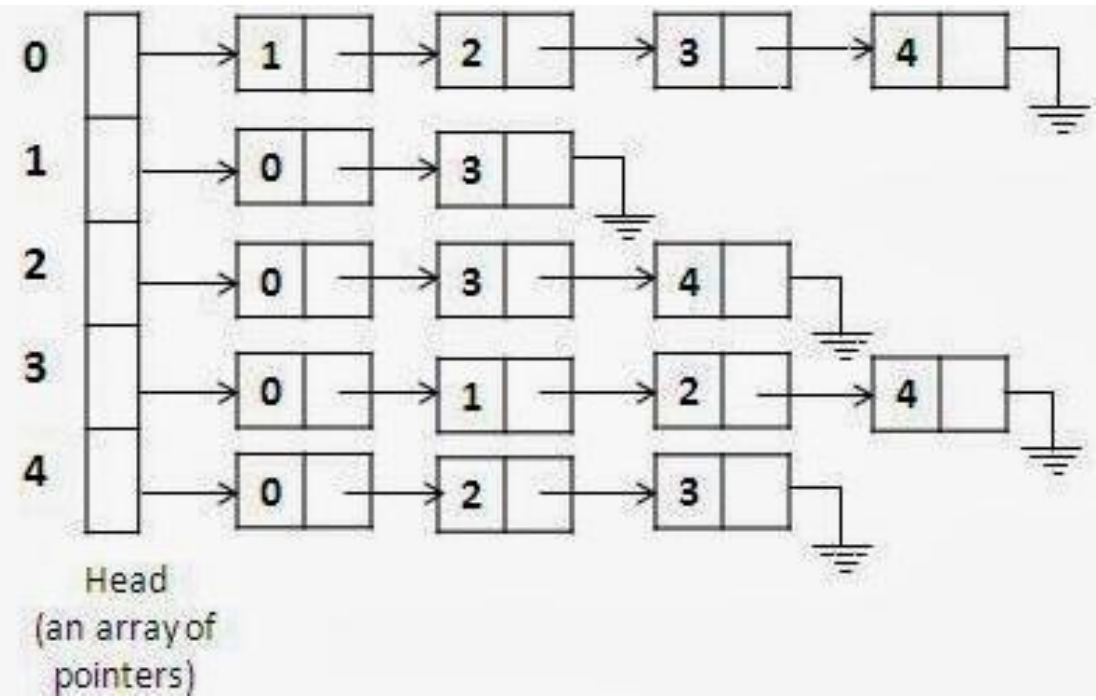
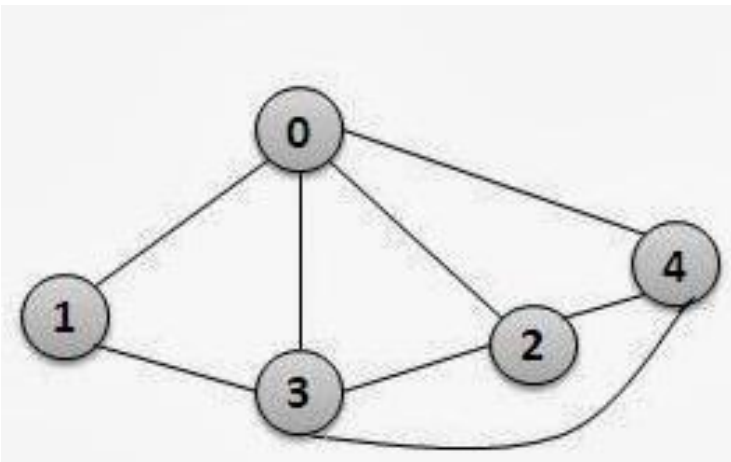

Contd...

- Directed graph

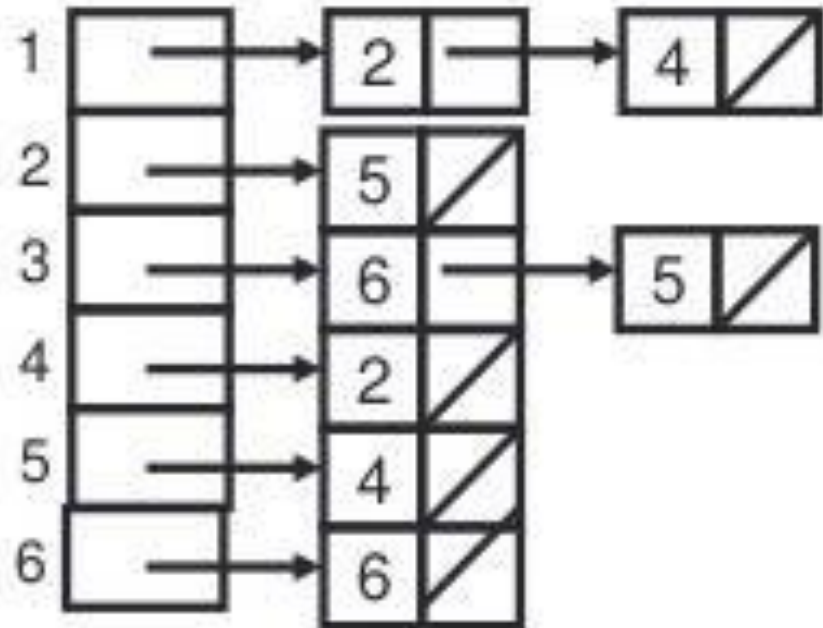
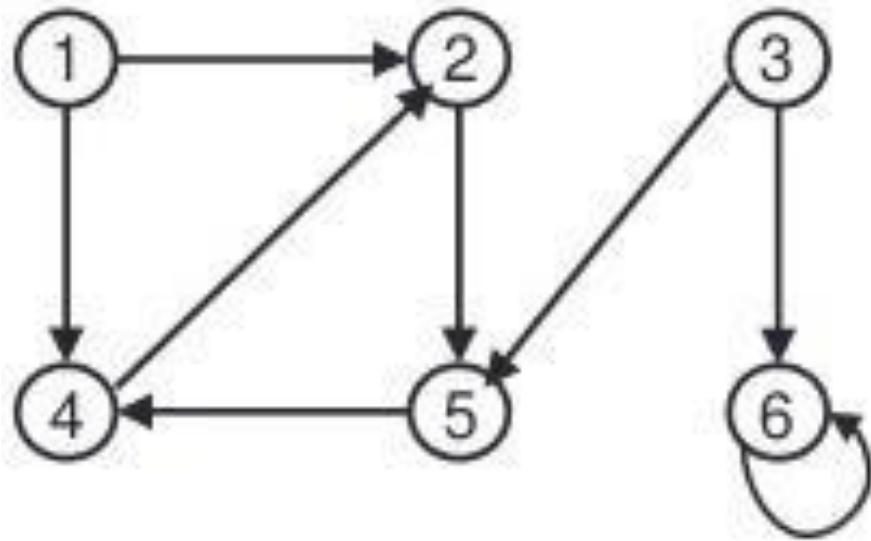

Contd...

- Weighted directed graph

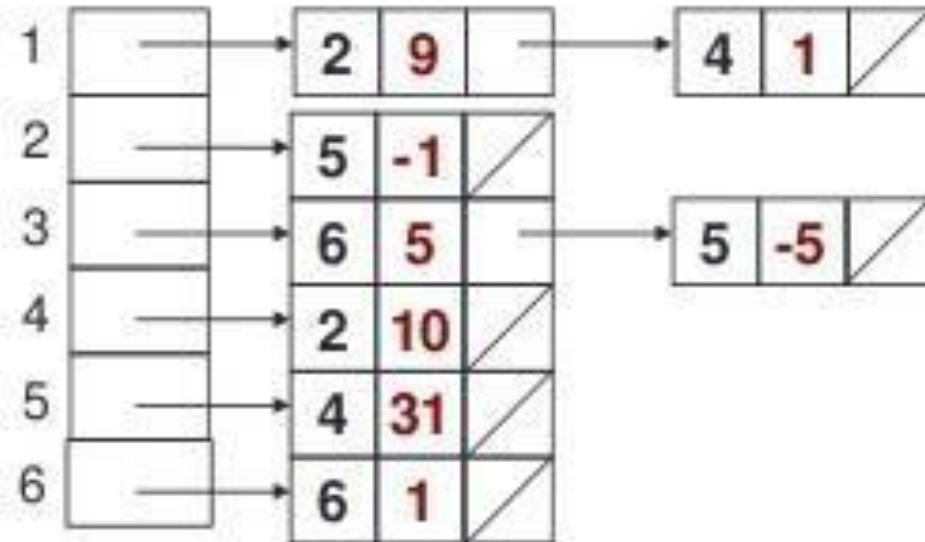
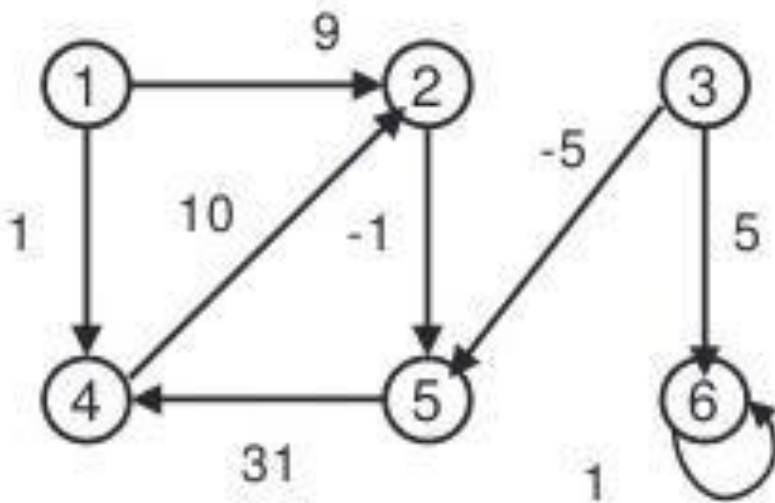

Pros and Cons

	Adjacency Matrix	Adjacency List
Memory Requirement	$O(V ^2)$	$O(V + E)$
Add Edge	$O(1)$	$O(1)$
Remove Edge	$O(1)$	$O(E)$
Find Edge Existence	$O(1)$	$O(V)$
Find # of Edges	$O(V ^2)$	$O(E)$
Add Vertex	$O(V ^2)$	$O(V)$
Remove Vertex	$O(V ^2)$	$O(E)$
Visit Adjacent Vertices	$O(V)$	$O(\text{Degree of that node})$

Some Definitions

- Walk
 - An alternating sequence of vertices and connecting edges.
 - Can end on the same vertex on which it began or on a different vertex.
 - Can travel over any edge and any vertex any number of times.
- Path
 - A walk that does not include any vertex twice, except that its first and last vertices might be the same.

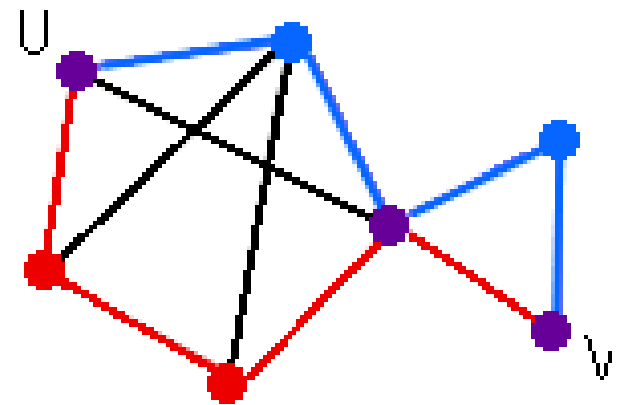

Contd...

- Trail

- A walk that does not pass over the same edge twice.
- Might visit the same vertex twice, but only if it comes and goes from a different edge each time.

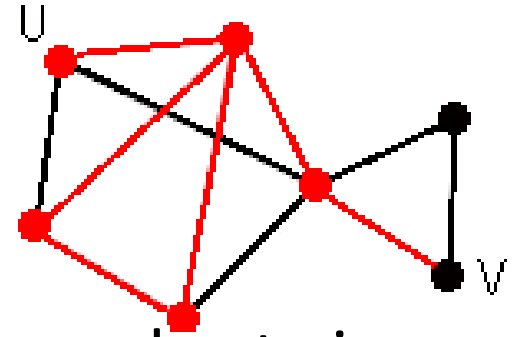

- Cycle

- Path that begins and ends on the same vertex.

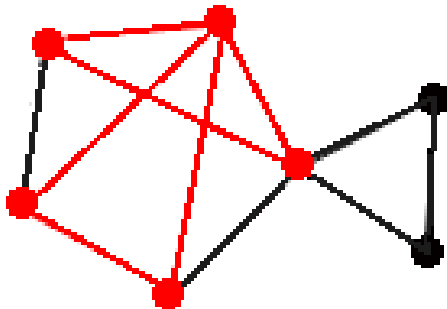
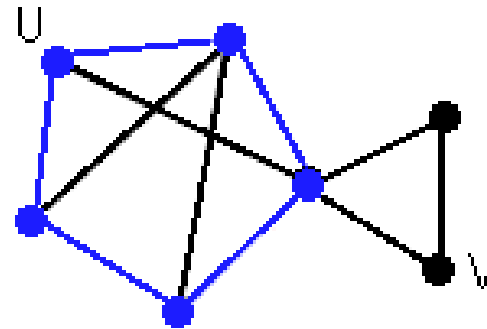

- Circuit

- Trail that begins and ends on the same vertex.

Euler Graphs

- An **Eulerian trail** (or **Eulerian path**) is a trail in a graph which visits every edge exactly once.
- An **Eulerian circuit** (or **Eulerian cycle**) is an Eulerian trail which starts and ends on the same vertex.
- A graph containing an Eulerian circuit is called **Euler graph**.
- A connected graph G is an Euler graph if and only if all vertices of G are of even degree.

Example

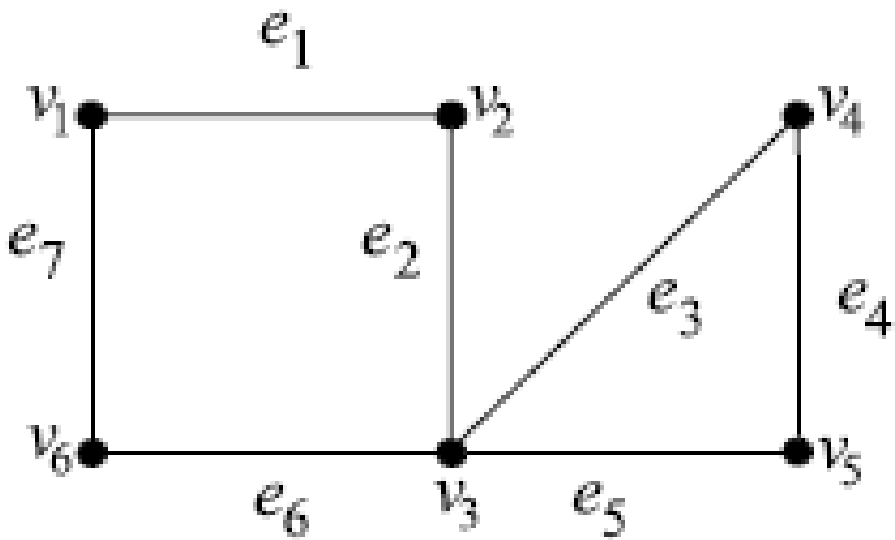

Eulerian graph as Euler circuit exists.

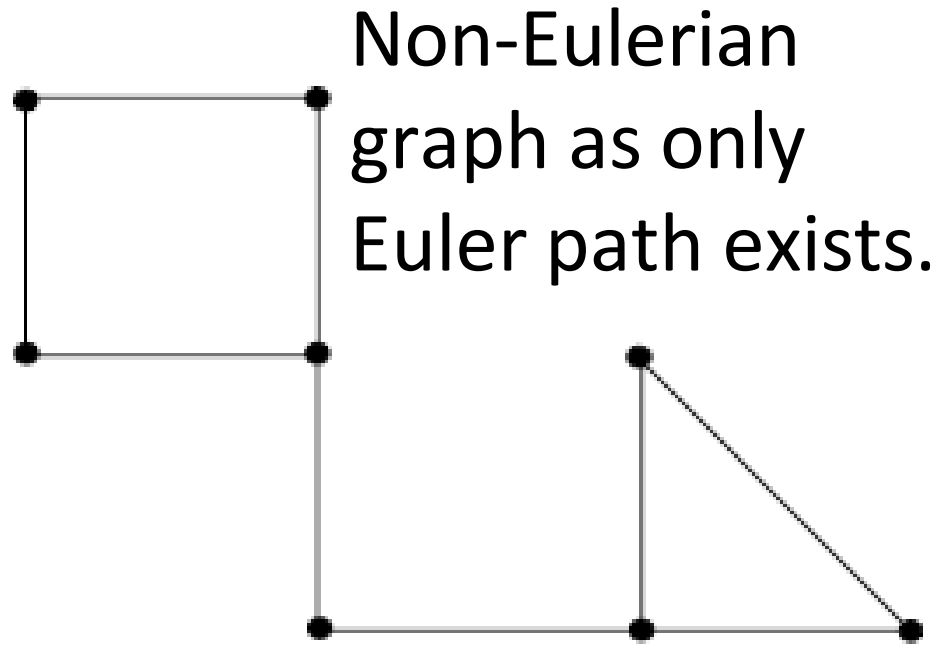

Non-Eulerian graph as only Euler path exists.

Fleury's algorithm

1. Start at a vertex of odd degree (Euler path), or, if the graph has none, start with an arbitrarily chosen vertex (Euler circuit).
2. Choose the next edge in the path to be one whose deletion would not disconnect the graph. (Always choose the non-bridge in between a bridge and a non-bridge.)
3. Add that edge to the circuit, and delete it from the graph.
4. Continue until the circuit is complete.

Example – 1

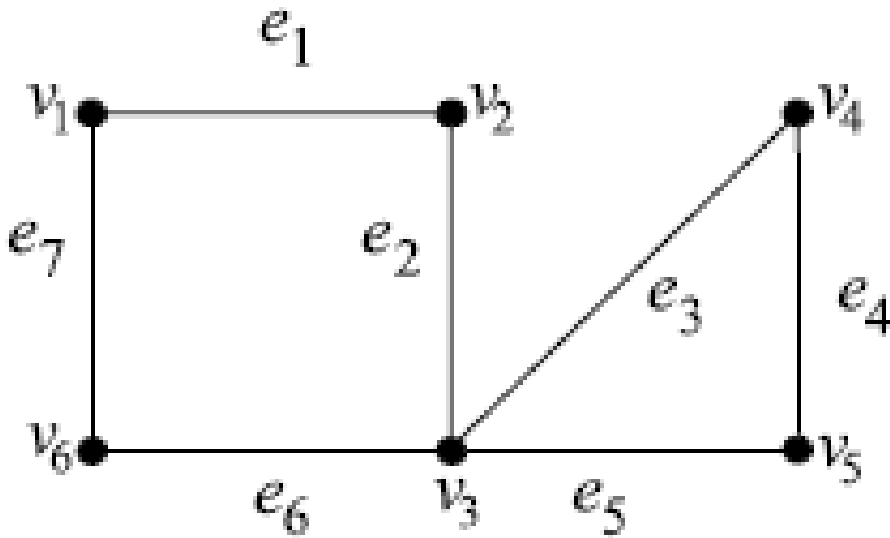

Vertex	Degree
v_1	2
v_2	2
v_3	4
v_4	2
v_5	2
v_6	2

- As degree of each vertex is even, thus Euler circuit exists.

Contd...

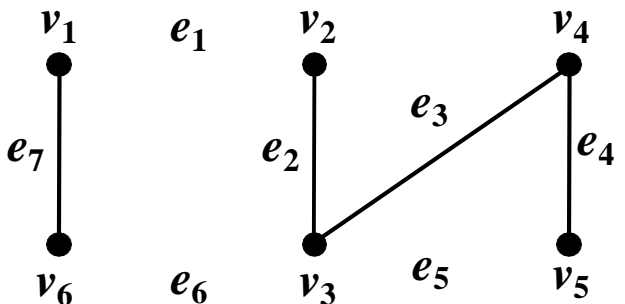
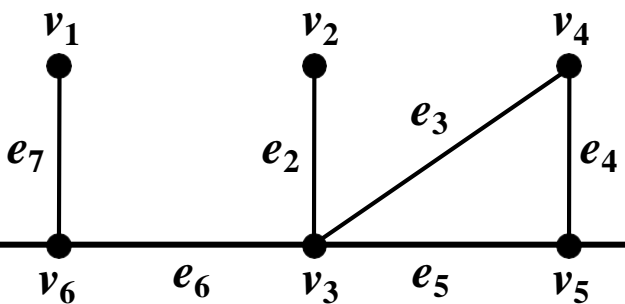
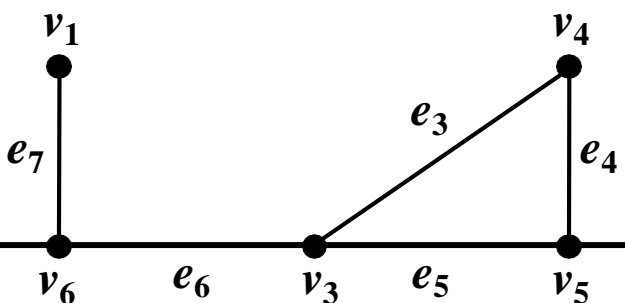
Graph	Current Vertex	Trail
	v_1	NULL
	v_2	v_1v_2 or e_1
	v_3	$v_1v_2v_3$ or e_1e_2

Contd...

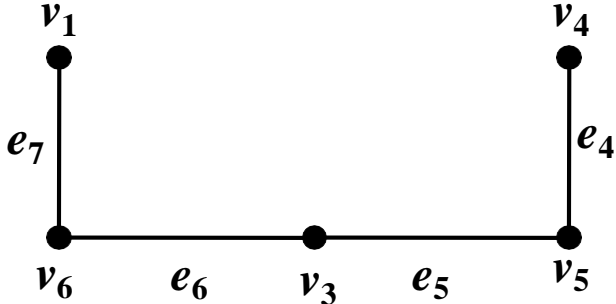
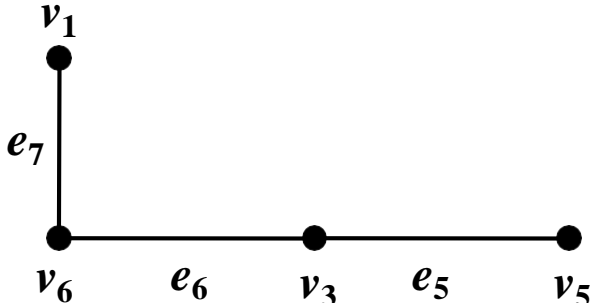
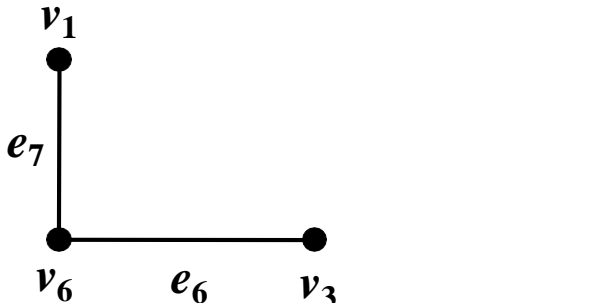
Graph	Current Vertex	Trail
	<p style="text-align: center;">v_4</p> <p>v_3v_6 or e_6 is a bridge and can't be selected.</p>	<p>$v_1v_2v_3v_4$ or $e_1e_2e_3$</p>
	<p style="text-align: center;">v_5</p>	<p>$v_1v_2v_3v_4v_5$ or $e_1e_2e_3e_4$</p>
	<p style="text-align: center;">v_3</p>	<p>$v_1v_2v_3v_4v_5v_3$ or $e_1e_2e_3e_4e_5$</p>

Contd...

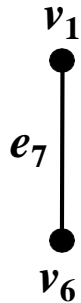
Graph	Current Vertex	Trail
	v_6	$v_1v_2v_3v_4v_5v_3v_6$ or $e_1e_2e_3e_4e_5e_6$
NULL	v_1	$v_1v_2v_3v_4v_5v_3v_6v_1$ or $e_1e_2e_3e_4e_5e_6e_7$

- Required Trail:

$v_1v_2v_3v_4v_5v_3v_6v_1$

or $e_1e_2e_3e_4e_5e_6e_7$

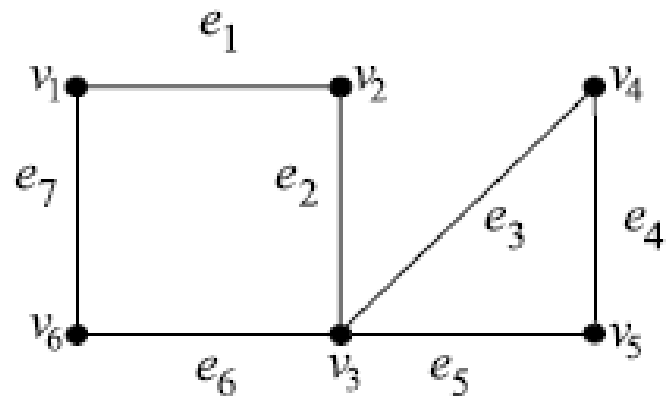

Example – 2

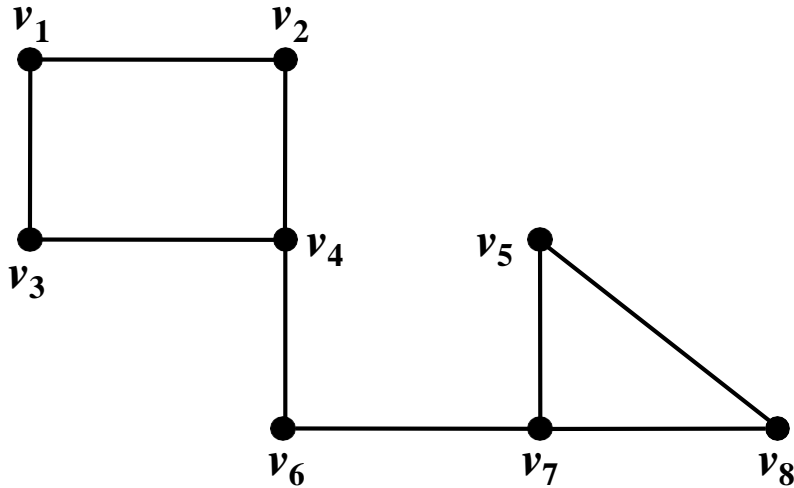

Vertex	Degree
v_1	2
v_2	2
v_3	4
v_4	3
v_5	2
v_6	2
v_7	3
v_8	2

- As degree of all the vertices is even except two (v_4 or v_7), thus Euler path exists.
- Start either from v_4 or v_7 .

Contd...

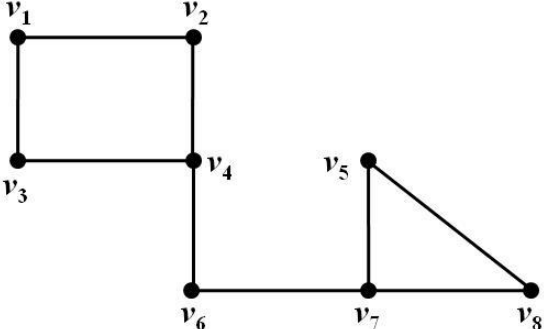
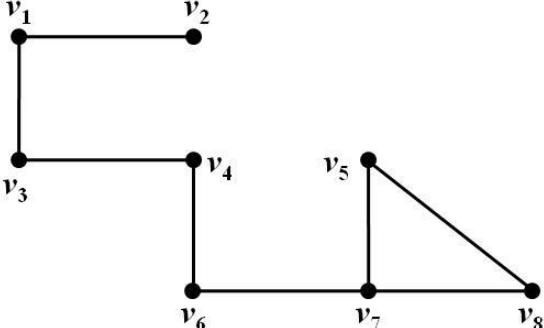
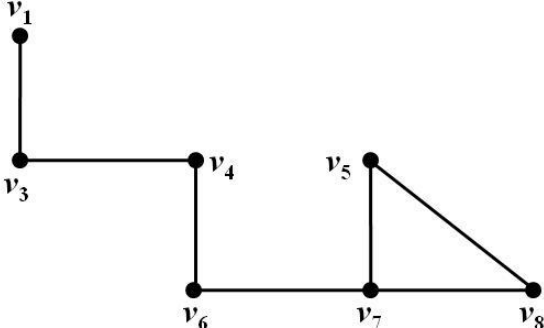
Graph	Current Vertex	Trail
	v_4	NULL
	v_2 v_4v_6 is a bridge and can't be selected.	v_4v_2
	v_1	$v_4v_2v_1$

Contd...

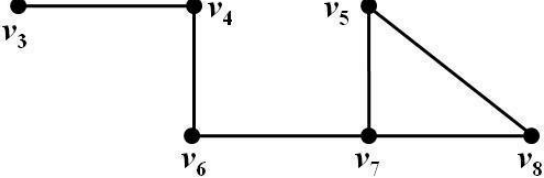
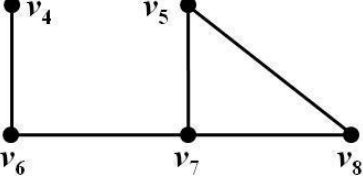
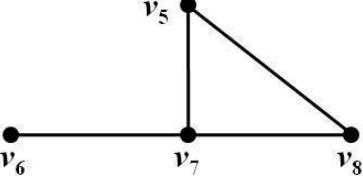
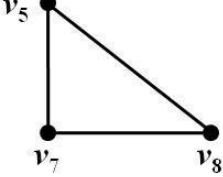
Graph	Current Vertex	Trail
	v_3	$v_4v_2v_1v_3$
	v_4	$v_4v_2v_1v_3v_4$
	v_6	$v_4v_2v_1v_3v_4v_6$
	v_7	$v_4v_2v_1v_3v_4v_6v_7$

Contd...

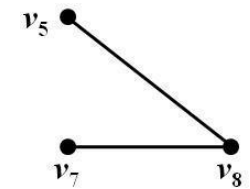
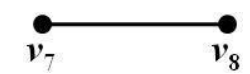
Graph	Current Vertex	Trail
	v_5	$v_4v_2v_1v_3v_4v_6v_7v_5$
	v_8	$v_4v_2v_1v_3v_4v_6v_7v_5v_8$
NULL	v_7	$v_4v_2v_1v_3v_4v_6v_7v_5v_8v_7$

• Required Trail:

$v_4v_2v_1v_3v_4v_6v_7v_5v_8v_7$

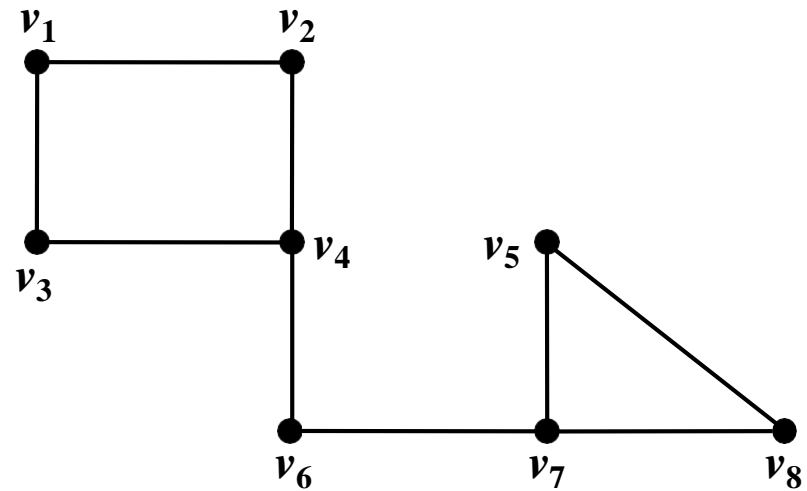

Example – 3

- Find Euler circuit using Fleury's algorithm. Start at vertex A.

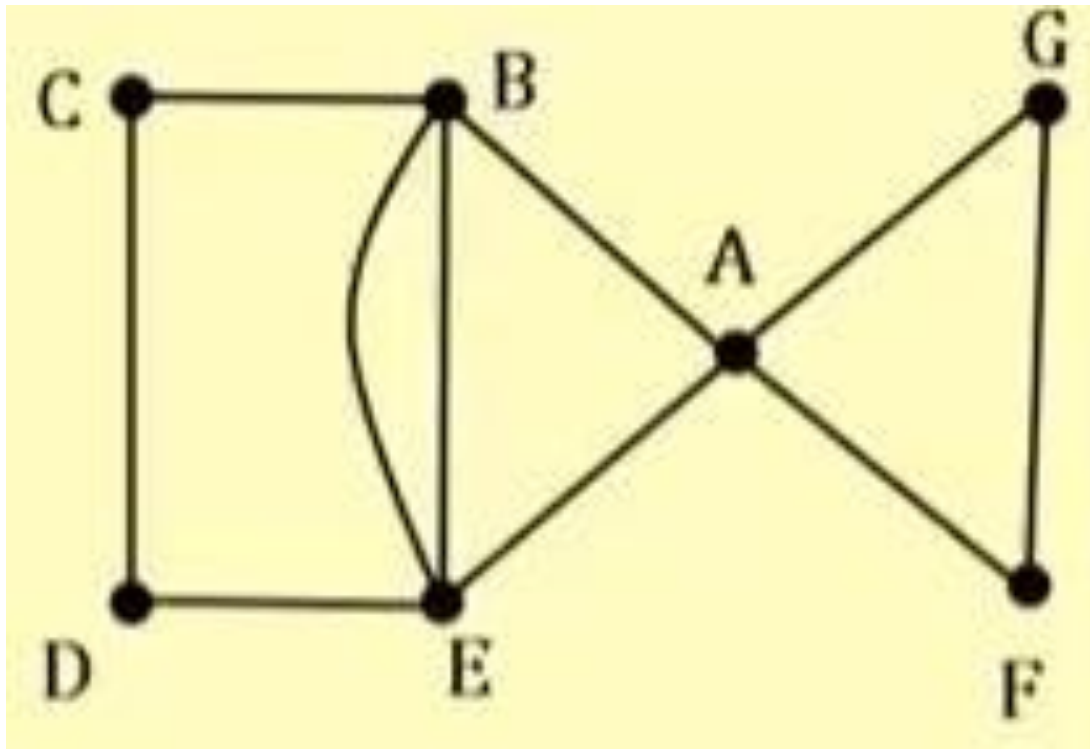

<https://www.youtube.com/watch?v=vvP4Fg4r-Ns>

Contd...

- In Fleury's algorithm, the graph traversal is linear in the number of edges, i.e. $O(|E|)$, excluding the complexity of detecting bridges.
- With Tarjan's linear time bridge-finding algorithm, the time complexity is $O(|E|^2)$.
- With Thorup's dynamic bridge-finding algorithm, the time complexity gets improved to $O(|E|(\log |E|)^3 \log \log |E|)$.

Hierholzer's algorithm

1. Choose any starting vertex v , and follow a trail of edges from that vertex until returning to v . The tour formed in this way is a closed tour, but may not cover all the vertices and edges of the initial graph.
2. As long as there exists a vertex u that belongs to the current tour but that has adjacent edges not part of the tour, start another trail from u , following unused edges until returning to u , and join the tour formed in this way to the previous tour.

Example – 1

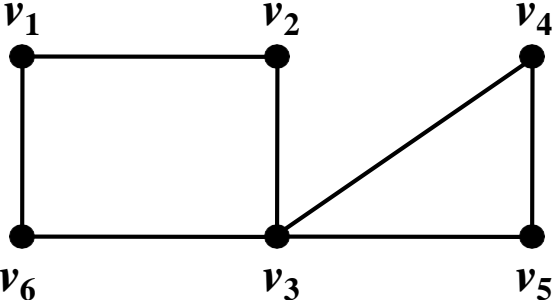
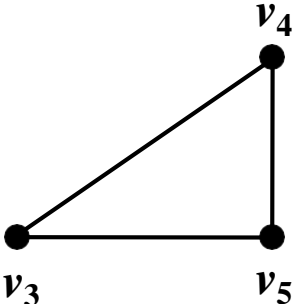
Graph	Trail
	$v_1 v_2 \underline{v_3} v_6 v_1$
	$v_1 v_2 v_3 v_4 v_5 v_3 v_6 v_1$
<p>Null</p>	<p>Required Trail:</p> $v_1 v_2 v_3 v_4 v_5 v_3 v_6 v_1$

Example – 2

- Find Euler circuit using Hierholzer's algorithm. Start at vertex A.

- Solution:
 - ABCDEA
 - AGFABCDEA
 - AGFABEBCDEA

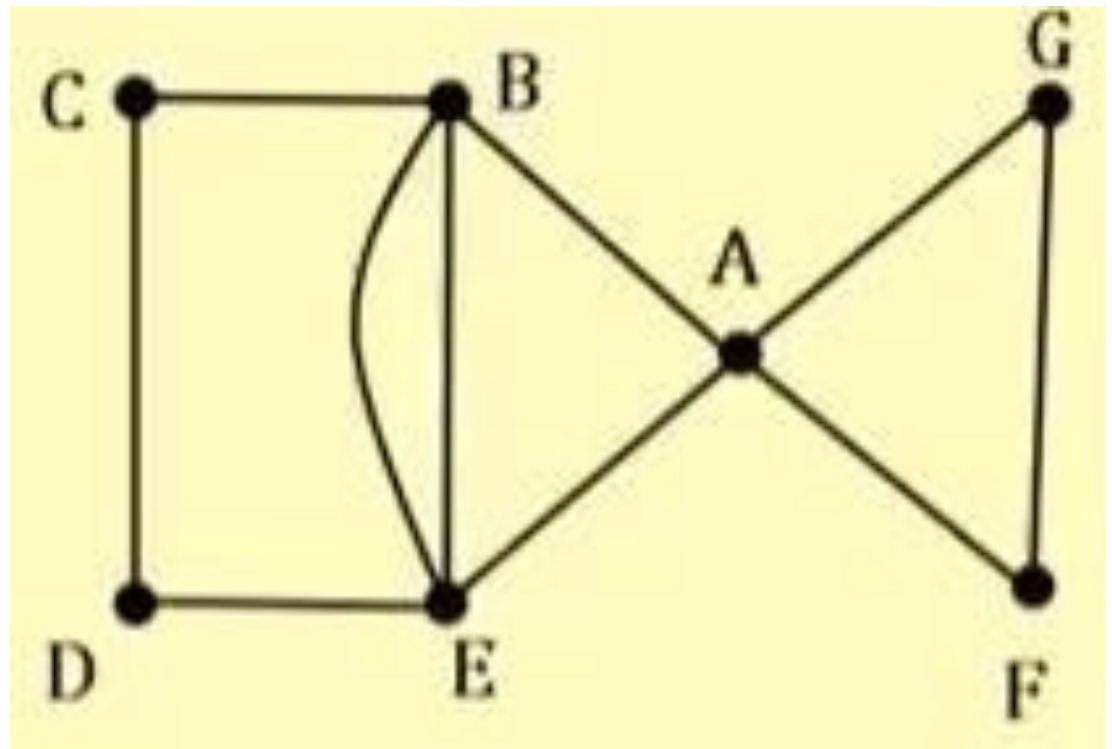

Contd...

- If doubly linked list is used to maintain
 - The set of unused edges incident to each vertex,
 - The list of vertices on the current tour that have unused edges, and
 - The tour itself.
- The individual operations of finding
 - Unused edges exiting each vertex,
 - A new starting vertex for a tour, and
 - Connecting two tours that share a vertex.
- May be performed in constant time, so the algorithm takes linear time, $O(|E|)$.

Hamiltonian Graphs

- A path passing through all the vertices of a graph is called a **Hamiltonian path**.
 - A graph containing a Hamiltonian path is said to be traceable.
- A cycle passing through all the vertices of a graph is called a **Hamiltonian cycle** (or **Hamiltonian circuit**).
- A graph containing a Hamiltonian cycle is called a **Hamiltonian graph**.
- **Hamiltonian path problem**: Determine the existence of Hamiltonian paths and cycles in graphs (**NP-complete**).

Example

- Not Hamiltonian graphs.

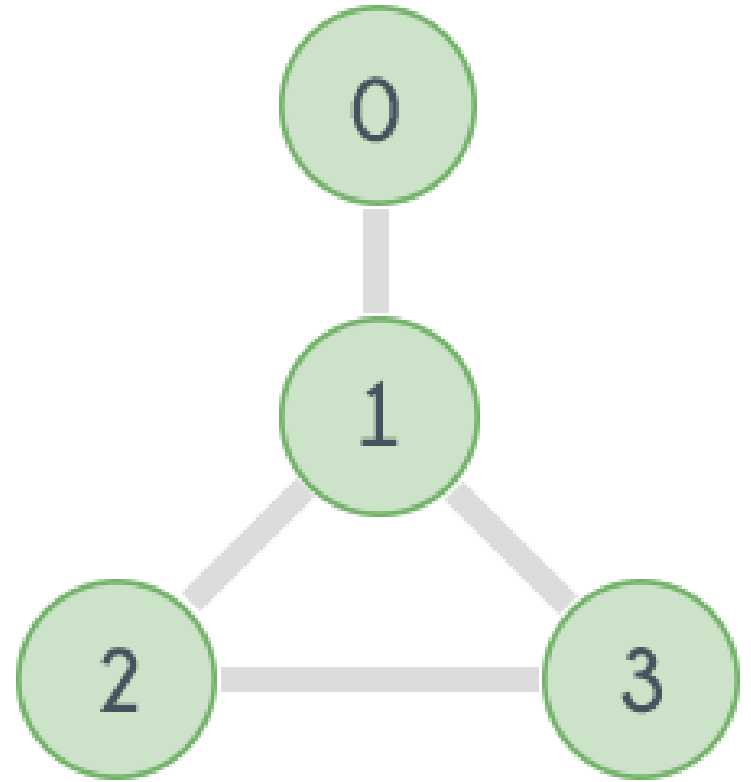
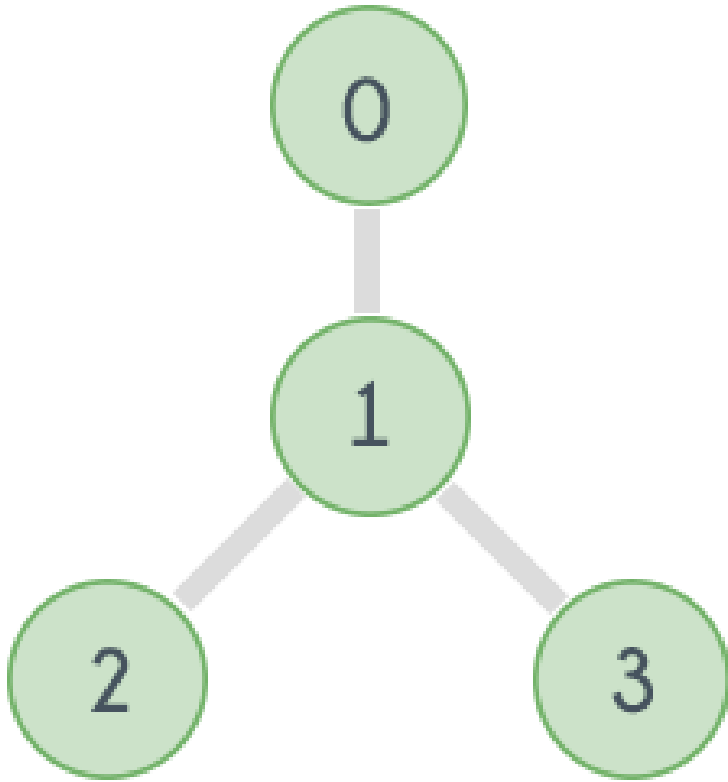

Example

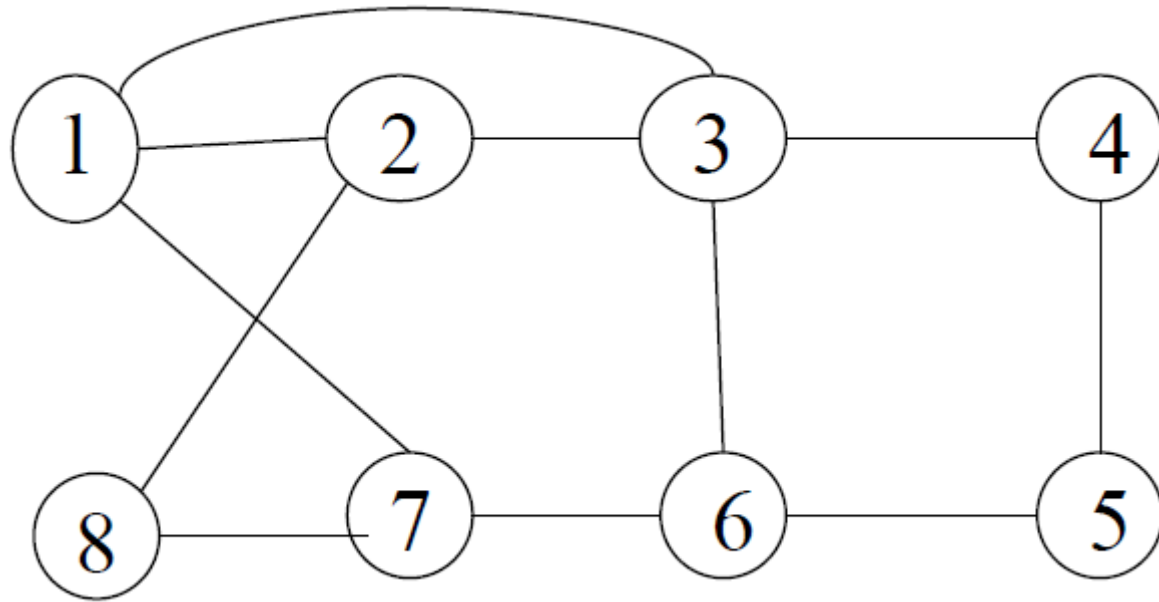

- Hamiltonian graph
– 128765431

Not a Hamiltonian graph.

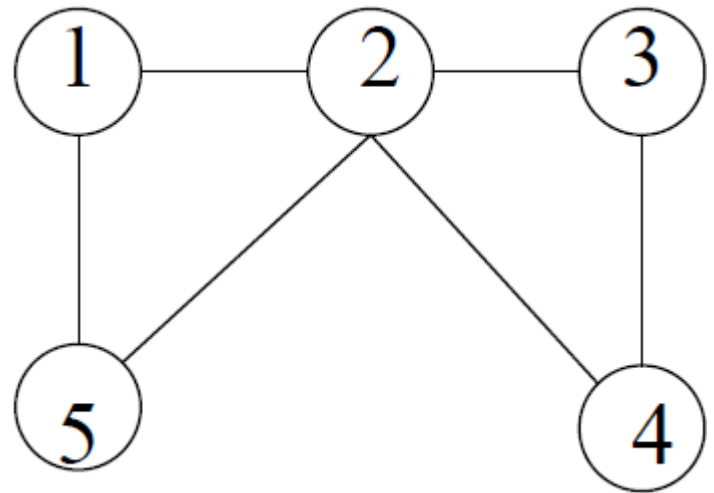

Solution 1 – Brute Force Search Algorithm

- A Hamiltonian Path in a graph having N vertices is nothing but a permutation of the vertices of the graph

$$[v_1, v_2, v_3, \dots, v_{N-1}, v_N]$$

such that there is an edge between v_i and v_{i+1} where $1 \leq i \leq N-1$.

- So it can be checked for all permutations of the vertices whether any of them represents a Hamiltonian Path or not.

Contd...

```
function check_all_permutations(adj[][], n)
  for i = 0 to n
    p[i]=i
  while next permutation is possible
    valid = true
    for i = 0 to n-1
      if adj[p[i]][p[i+1]] == false
        valid = false
        break
    if valid == true
      print_permutation(p)
      return true
    p = get_next_permutation(p)
  return false
```

Example

Not a Hamiltonian graph as path exists and not a circuit.

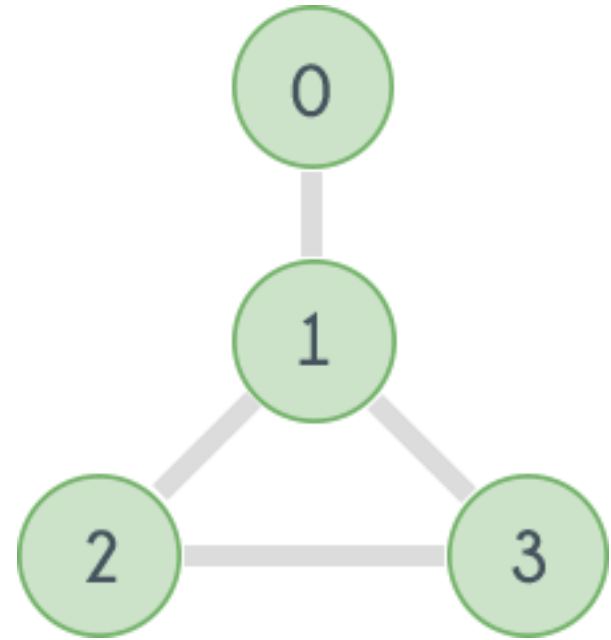

- | | | | |
|--------------------------|--------------------|---------------------------|---------------------------|
| 1. 0-1-2-3 | 7. 1-0-2-3 | 13. 2-0-1-3 | 19. 3-0-1-2 |
| 2. 0-1-3-2 | 8. 1-0-3-2 | 14. 2-0-3-1 | 20. 3-0-2-1 |
| 3. 0-2-1-3 | 9. 1-2-0-3 | 15. 2-1-0-3 | 21. 3-1-0-2 |
| 4. 0-2-3-1 | 10. 1-2-3-0 | 16. 2-1-3-0 | 22. 3-1-2-0 |
| 5. 0-3-1-2 | 11. 1-3-0-2 | 17. 2-3-1-0 | 23. 3-2-0-1 |
| 6. 0-3-2-1 | 12. 1-3-2-0 | 18. 2-3-0-1 | 24. 3-2-1-0 |

Solution 2 – Backtracking

1. Create an empty path array and add vertex 0 to it.
2. Add other vertices, starting from the vertex 1.
3. Before adding a vertex, check for whether it is adjacent to the previously added vertex and not already added.
4. If such a vertex is found, add that vertex as part of the solution.
5. Otherwise, return false.

Contd...

```
1. bool hamCycle(bool graph[V][V])
2. { int *path = new int[V];
3.   for (int i = 0; i < V; i++)
4.     path[i] = -1;
5.
6.   path[0] = 0;
7.   if ( hamCycleUtil(graph, path, 1) == false )
8.     { printf("\nSolution does not exist");
9.       return false;
10.    }
11.   printSolution(path);
12.   return true; }
```

Contd...

```
1.  bool hamCycleUtil(bool graph[V][V], int path[], int pos)
2.  {  if (pos == V)
3.      {  if ( graph[ path[pos-1] ][ path[0] ] == 1 )
4.          return true;
5.      else
6.          return false;
7.      }
8.  for (int v = 1; v < V; v++)
9.      {  if (isSafe(v, graph, path, pos))
10.         {  path[pos] = v;
11.            if (hamCycleUtil (graph, path, pos+1) == true)
12.                return true;
13.            path[pos] = -1;
14.         }
15.      }
16.  return false;  }
```

Contd...

```
1. bool isSafe(int v, bool graph[V][V], int path[], int pos)
2. {
3.     if (graph [ path[pos-1] ][ v ] == 0)
4.         return false;
5.
6.     for (int i = 0; i < pos; i++)
7.         if (path[i] == v)
8.             return false;
9.
10.    return true;
11.}
```

Example

$\text{graph}[1][4] = 1.$

Thus Hamiltonian graph.

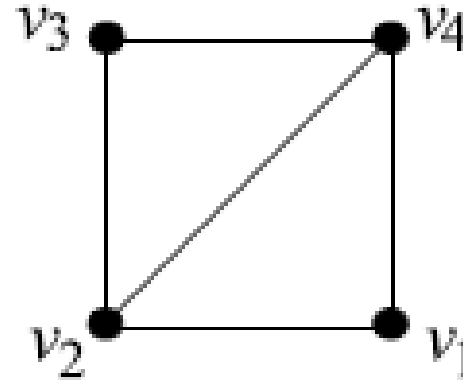

path[4]	4
3	3
2	2
1	1

	1	2	3	4
1	0	1	0	1
2	1	0	1	1
3	0	1	0	1
4	1	1	1	0

Applications

- Painting road lines,
- Plowing roads after a snowstorm,
- Checking meters along roads,
- Garbage pickup routes, etc.

Definitions

- Diagraph or directed graph.
- A cycle in a diagraph G is a set of edges, $\{(v_1, v_2), (v_2, v_3), \dots, (v_{r-1}, v_r)\}$ where $v_1 = v_r$.
- A diagraph is acyclic if it has no cycles. Also known as directed acyclic graph (**DAG**).
- DAGs are used in many applications to indicate precedence among events. For example,
 - Inheritance between classes.
 - Prerequisites between courses of a degree program.
 - Scheduling constraints between the tasks of a projects.

Example – Prerequisites between courses

142 → 143 → 378 → 370 → 321 → 341 → 322 →
326 → 421 → 401

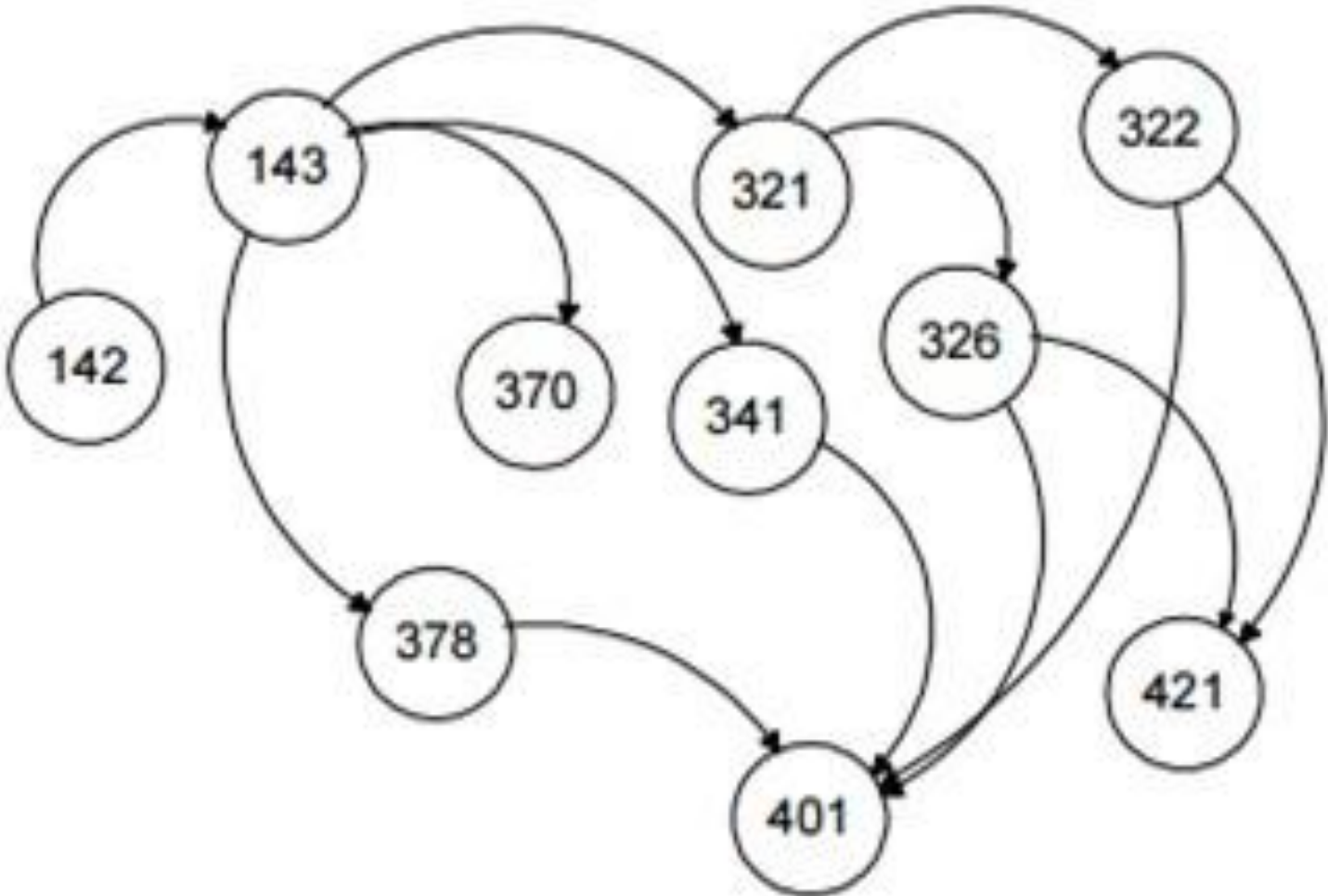

Example – Scheduling

TOPOLOGICAL SORT

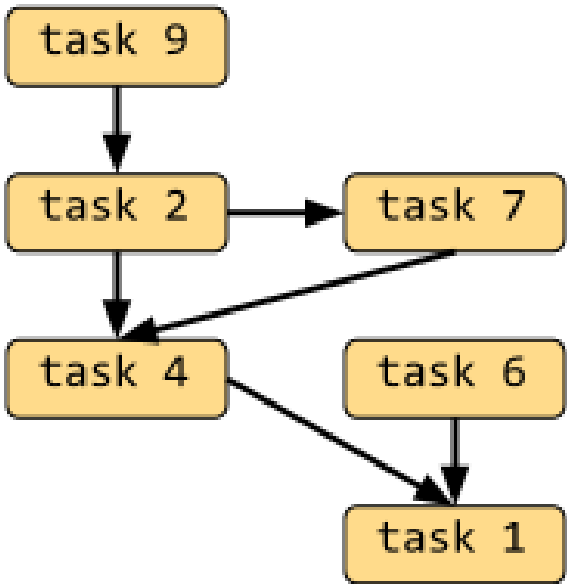

RIGHT

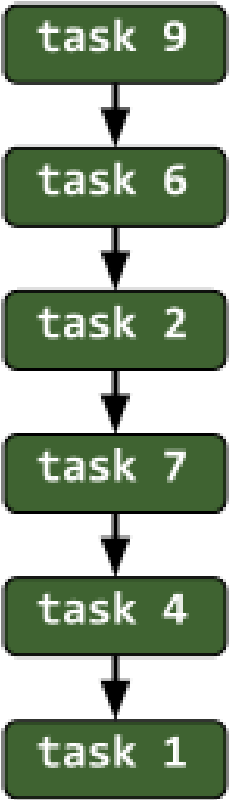

WRONG

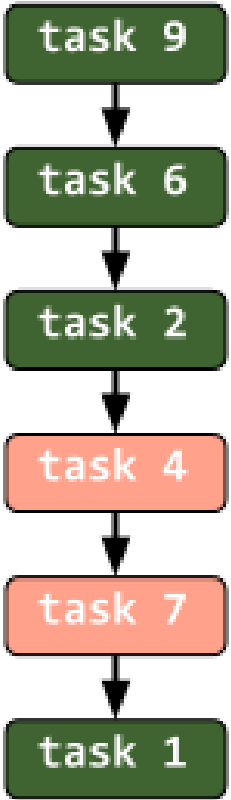

Topological Sort

- Let, $G = (V, E)$ be a DAG
- Linear ordering of all its vertices such that if G contains an edge (u, v) , then u appears before v in the ordering.
- Can also be viewed as an ordering of vertices along a horizontal line so that all directed edges go from left to right.

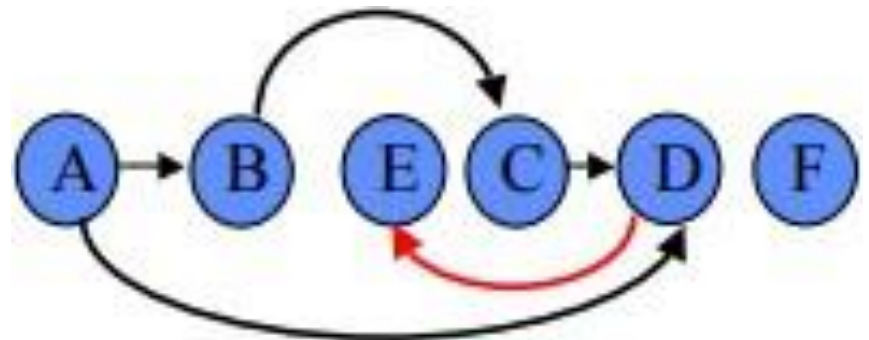
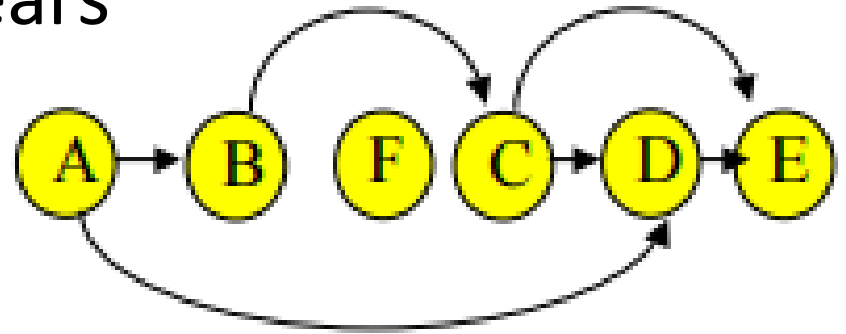
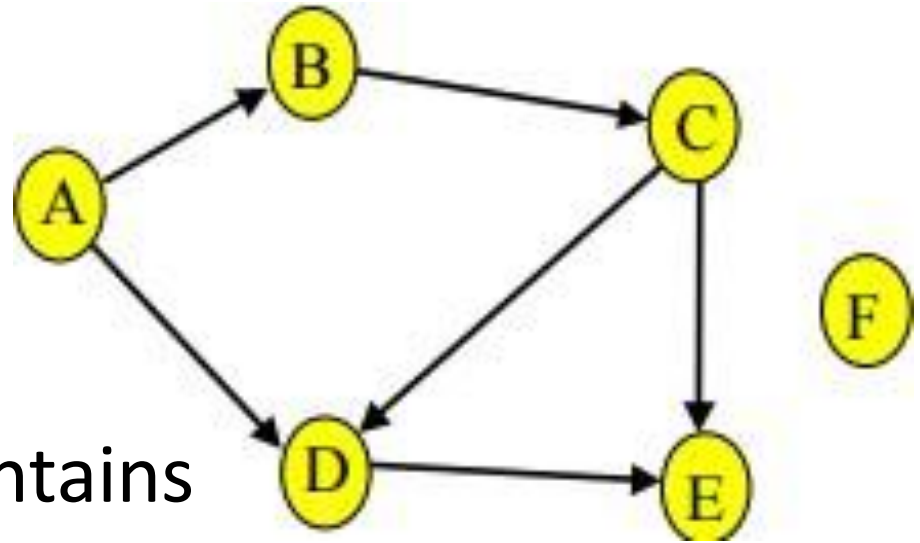

Kahn's algorithm

- $L \leftarrow$ Empty list that will contain the sorted elements
 - $S \leftarrow$ Set of all nodes with no incoming edge
1. **while** S is non-empty **do**
 2. remove a node n from S
 3. add n to *tail* of L
 4. **for each** node m with an edge e from n to m **do**
 5. remove edge e from the graph
 6. **if** m has no other incoming edges **then**
 7. insert m into S
 8. **if** graph has edges **then**
 9. return error (graph has at least one cycle)
 10. **else**
 11. return L (a topologically sorted order)

Example – 1

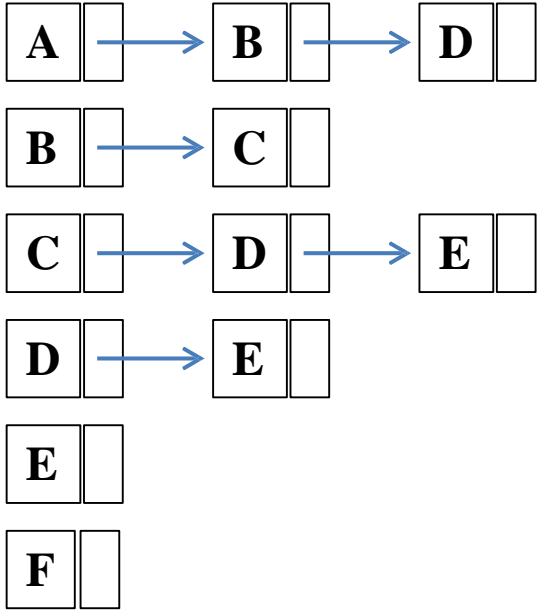
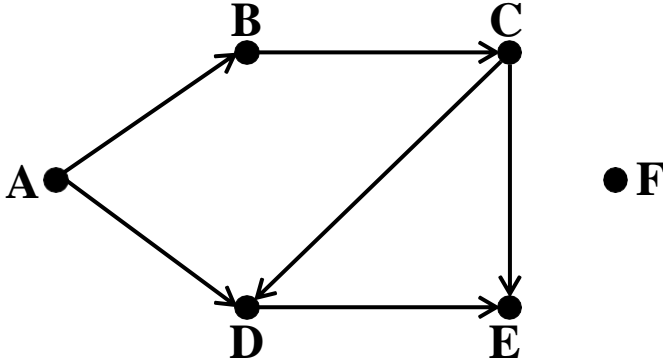

Vertex	In-degree
A	0
B	1
C	1
D	2
E	2
F	0

Contd...

L: \emptyset
 S: $A \rightarrow F$

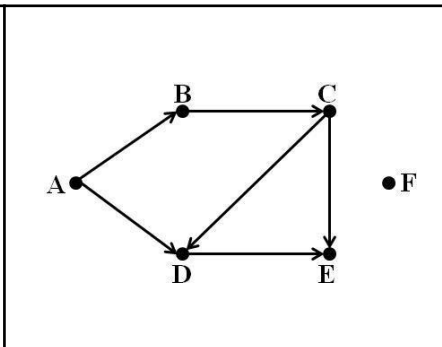

Vertex	In-degree
A	0
B	1
C	1
D	2
E	2
F	0

L: A
 S: $F \rightarrow B$

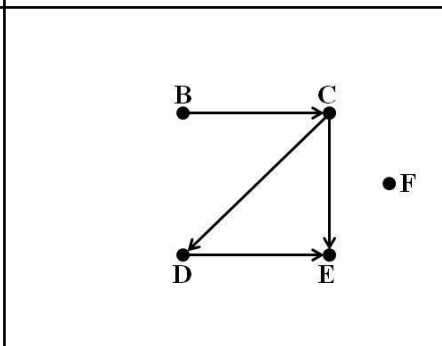

Vertex	In-degree
A	0
B	1 0
C	1
D	2 1
E	2
F	0

L: $A \rightarrow F$
 S: B

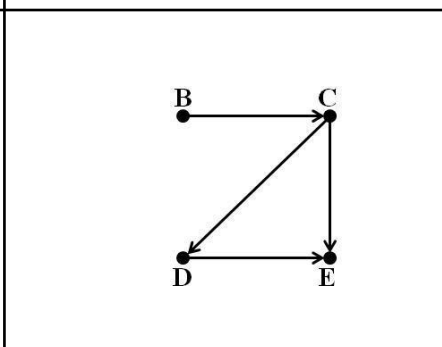

Vertex	In-degree
A	0
B	1 0
C	1
D	2 1
E	2
F	0

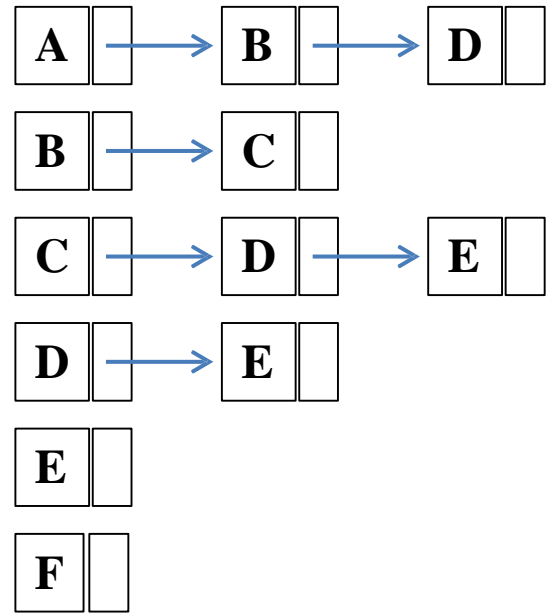

Contd...

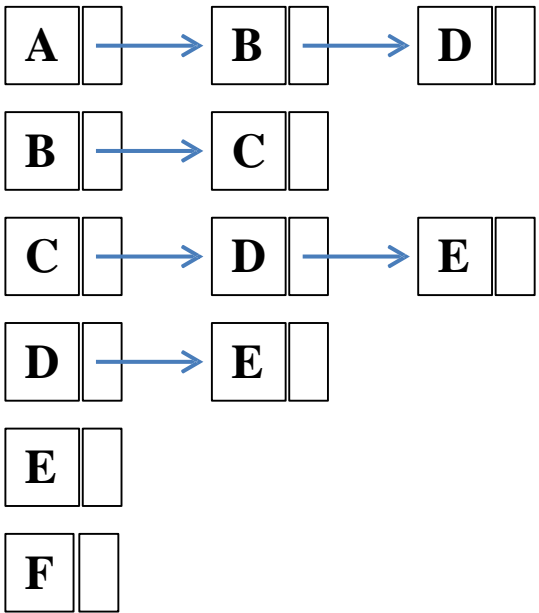

L: A → F → B
S: C

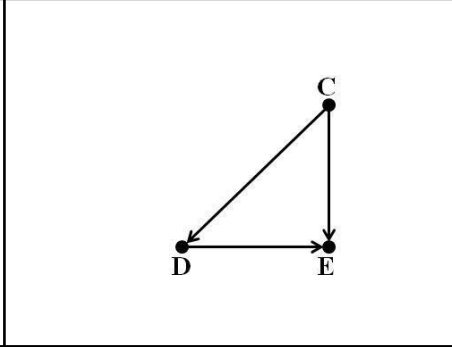

Vertex	In-degree
A	0
B	1 0
C	1 0
D	2 1
E	2
F	0

L: A → F → B → C
S: D

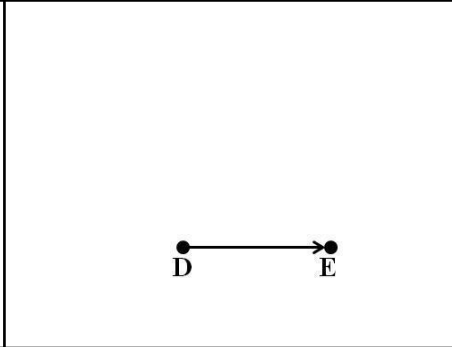

Vertex	In-degree
A	0
B	1 0
C	1 0
D	2 1 0
E	2 1
F	0

L: A → F → B → C → D
S: E

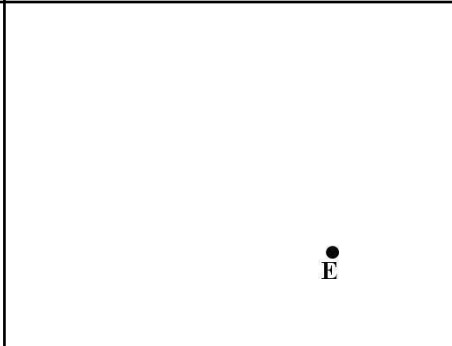

Vertex	In-degree
A	0
B	1 0
C	1 0
D	2 1 0
E	2 1 0
F	0

L: A → F → B → C → D → E
S: ∅

NULL

Required topological sort is
A F B C D E

Topological Sort using DFS

- Perform DFS. Sort vertices in decreasing order of their finishing time.

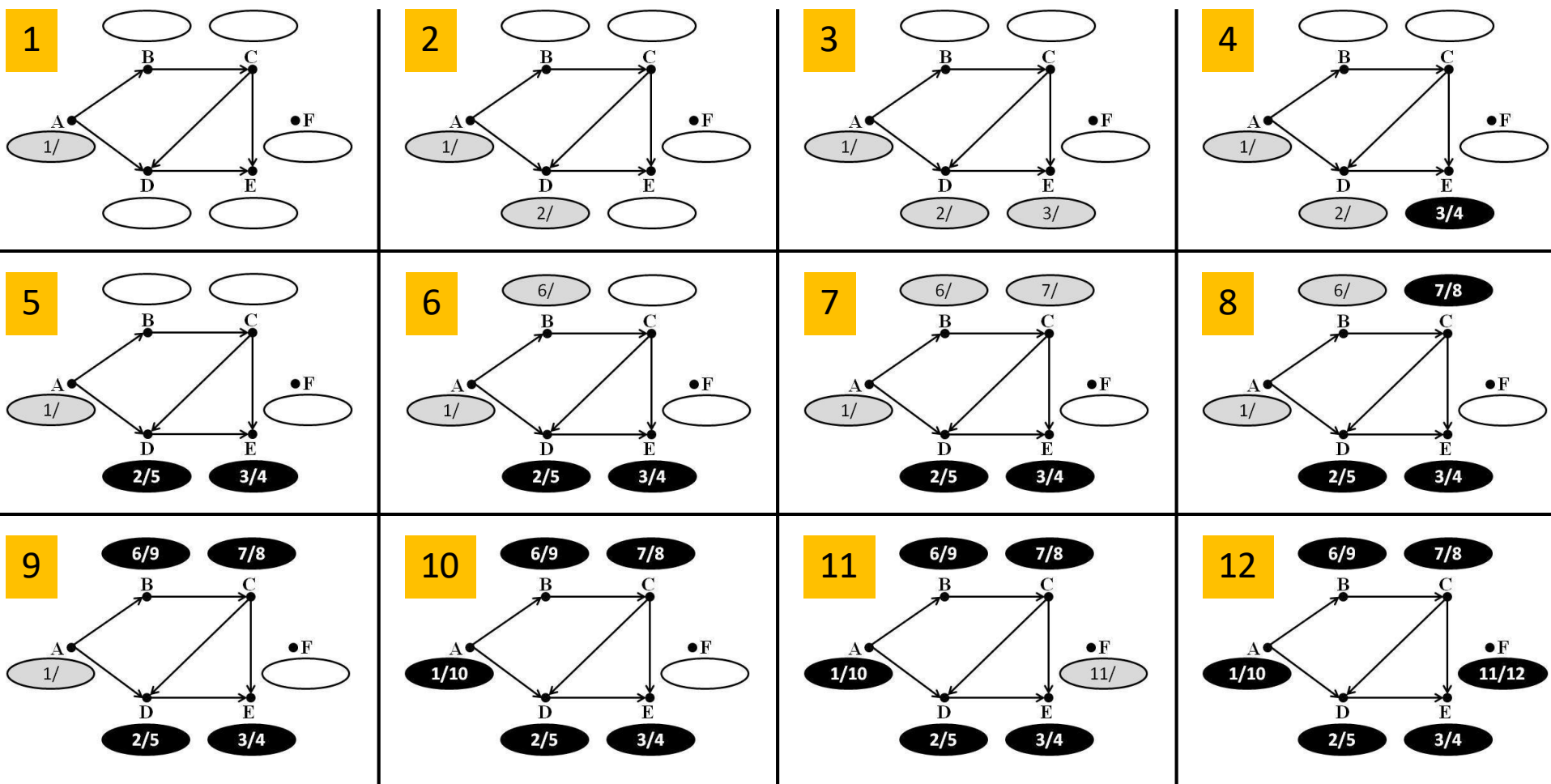

Contd...

Vertex	Starting Time	Finishing Time
A	1	10
B	6	9
C	7	8
D	2	5
E	3	4
F	11	12

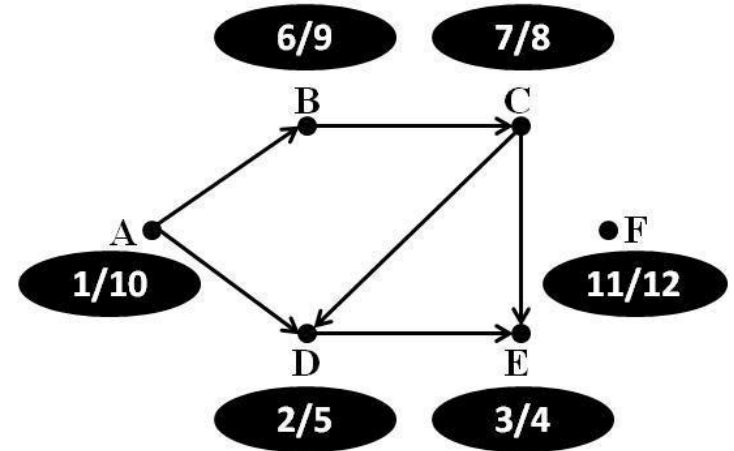

- Required topological sort is F A B C D E.

Topological Sort using DFS – Implementation

1. `T = []`
2. `visited = []`
3. `topological_sort(cur_vert, N, adj[][])`
4. `{ visited[cur_vert] = true`
5. `for i = 0 to N`
6. `if adj[cur_vert][i] is true and visited[i] is false`
7. `topological_sort(i, N, adj[][])`
8. `T.insert_in_beginning(cur_vert)`
9. `// T.push(cur_vert) }`

Example

• T[]:

5	4
4	5
3	2
2	3
1	1
0	0

4 → 5 → 2 → 3
 → 1 → 0

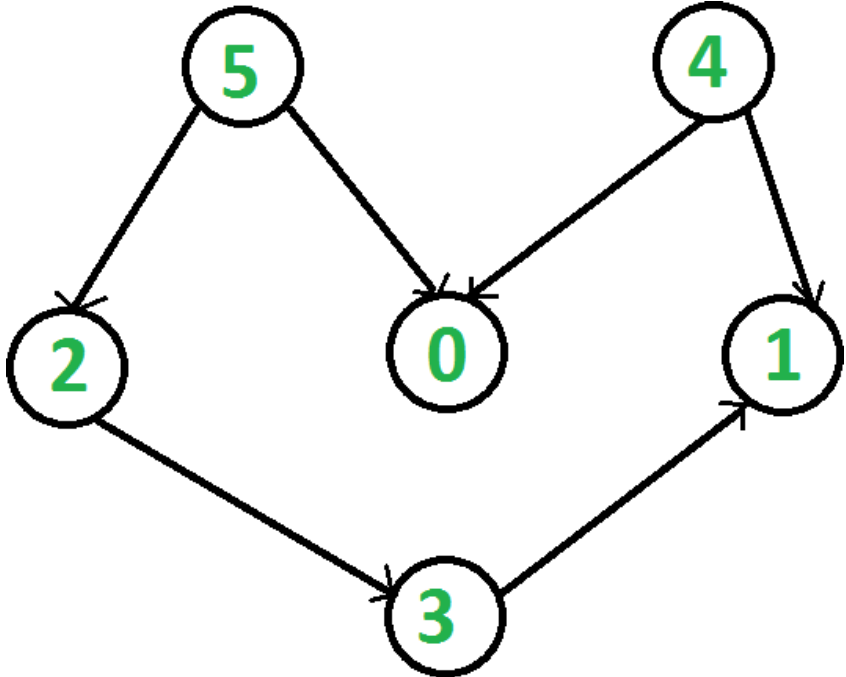

• Visited[]

		→						
5	0	1	1	1	1	1	1	
4	0	0	0	0	0	0	1	
3	0	0	0	0	1	1	1	
2	0	0	0	1	1	1	1	
1	0	0	0	0	0	1	1	
0	0	0	1	1	1	1	1	

	0	1	2	3	4	5
0	0	0	0	0	0	0
1	0	0	0	0	0	0
2	0	0	0	1	0	0
3	0	1	0	0	0	0
4	1	1	0	0	0	0
5	1	0	1	0	0	0

Example

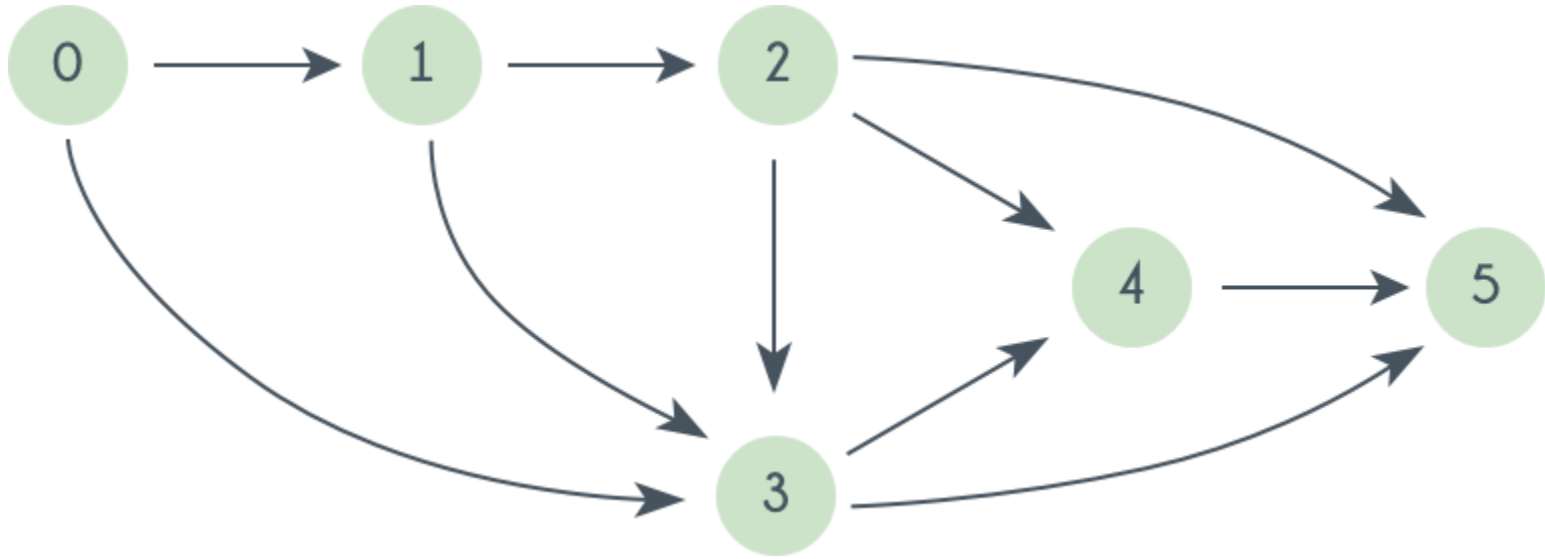

- Topological sort:

0 → 1 → 2 → 3 → 4 → 5

Connected and Disconnected Graph

- A graph is connected if all the vertices are connected to each other, i.e.
 - A path exists between every pair of vertices.
 - No unreachable vertices.
- A graph is disconnected if it is not connected.
- A graph with just one vertex is connected.
- An edgeless graph with two or more vertices is disconnected.

Example

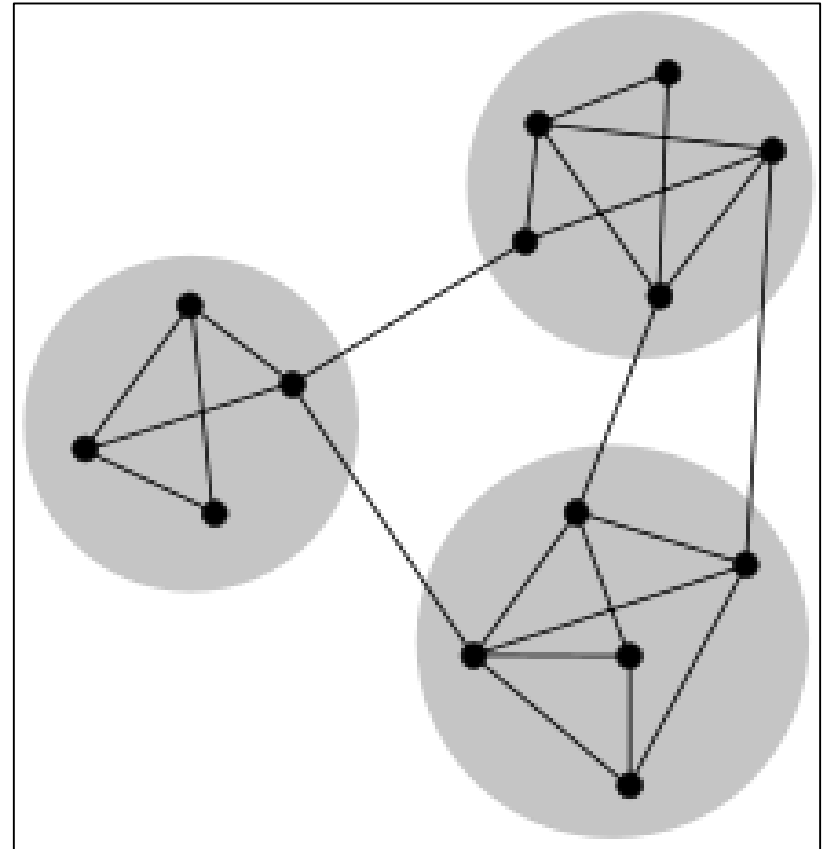
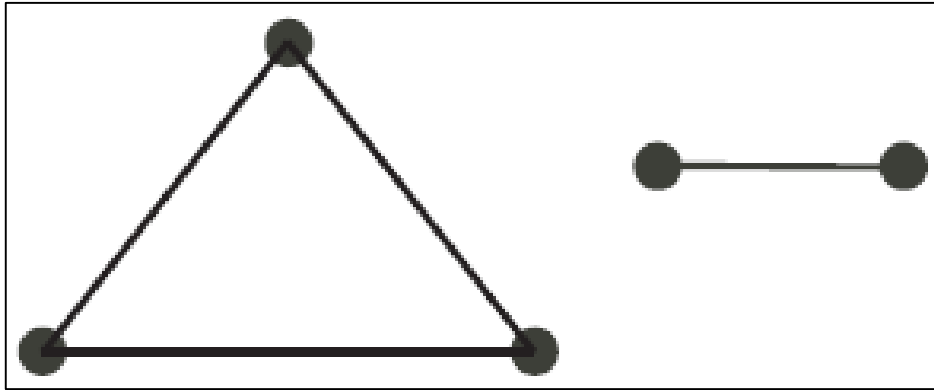

Cut Vertex

- A vertex v of a graph G is a cut vertex or an articulation vertex of G if the graph $G - v$ consists of a greater number of components than G .

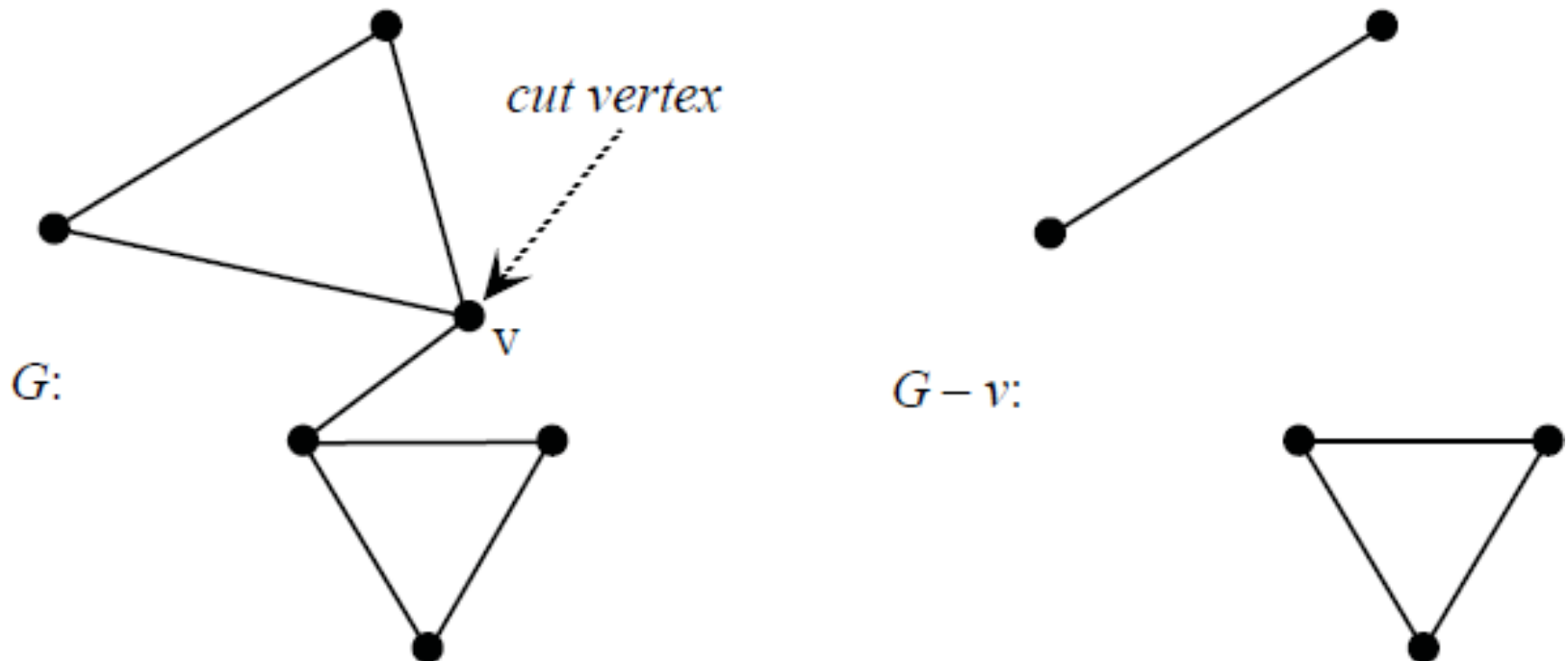

Contd...

- A graph is separable if it is not connected or if there exists at least one cut vertex in the graph.

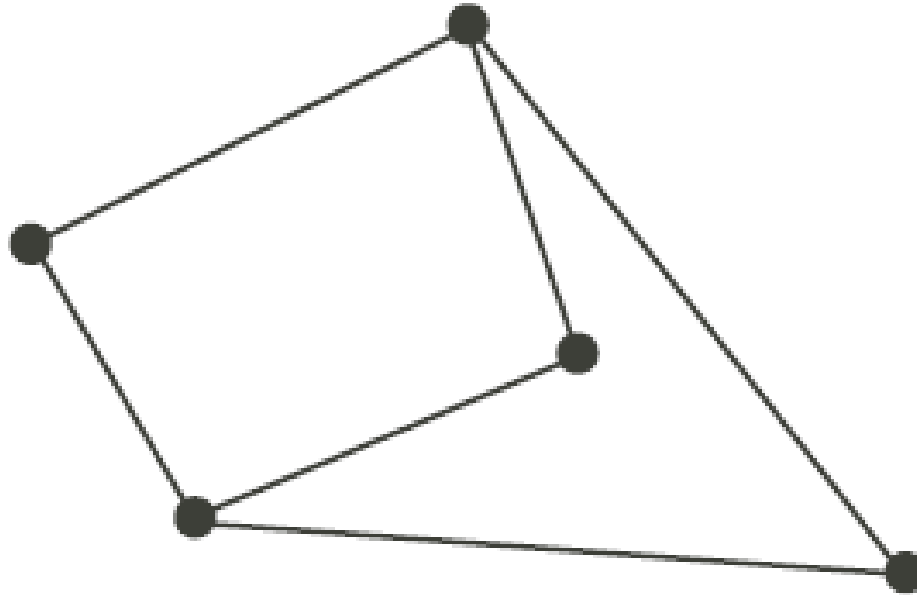

Cut-set

- A cut set of the connected graph $G = (V, E)$ is an edge set $F \subseteq E$ such that
 1. $G - F$ (remove the edges of F one by one) is not connected, and
 2. $G - H$ is connected whenever $H \subset F$.

Example

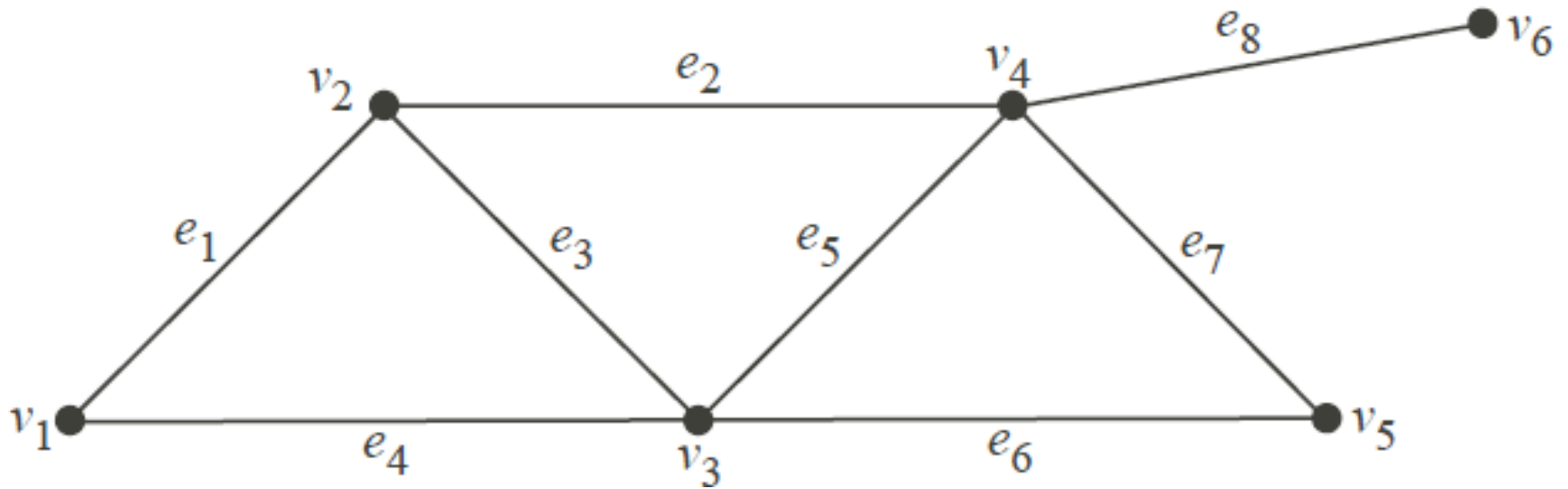

- $\{e_1, e_4\}$, $\{e_6, e_7\}$, $\{e_1, e_2, e_3\}$, $\{e_8\}$, $\{e_3, e_4, e_5, e_6\}$, $\{e_2, e_5, e_7\}$, $\{e_2, e_5, e_6\}$ and $\{e_2, e_3, e_4\}$.

Cut

- A cut is a partition of the vertices of a graph into two disjoint subsets.

- Formally,

In a graph $G = (V, E)$, a pair of subsets V_1 and V_2 of V satisfying

$$V = V_1 \cup V_2, V_1 \cap V_2 = \emptyset, V_1 \neq \emptyset, V_2 \neq \emptyset$$

is called a cut (or a partition) of G . Denoted as (V_1, V_2) .

- It is also defined as an edge set.

$\text{cut}(V_1, V_2) = \{\text{those edges with one end vertex in } V_1 \text{ and the other end vertex in } V_2\}$.

Contd...

- In an unweighted undirected graph, the size or weight of a cut is the number of edges crossing the cut.

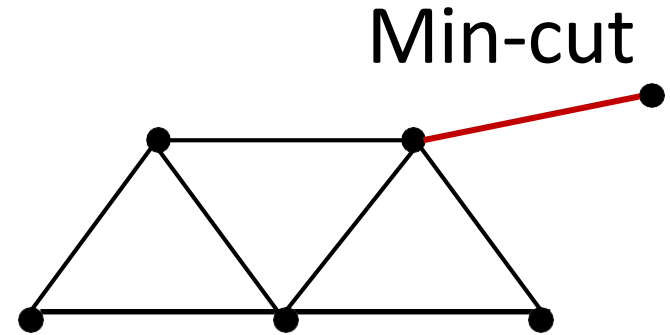

- In a weighted graph, the value or weight is defined by the sum of the weights of the edges crossing the cut.

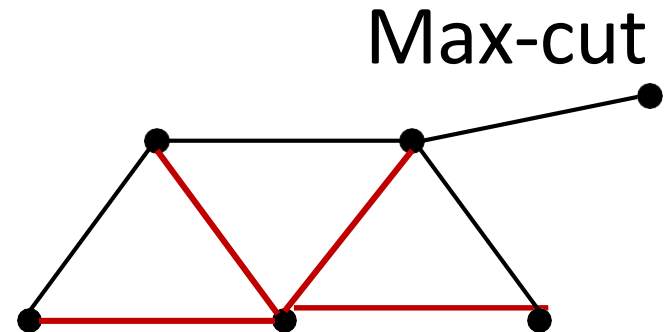

Strongly Connected Components

A subset of a directed graph is called strongly connected if there is a path in each direction between each pair of vertices of the subset.

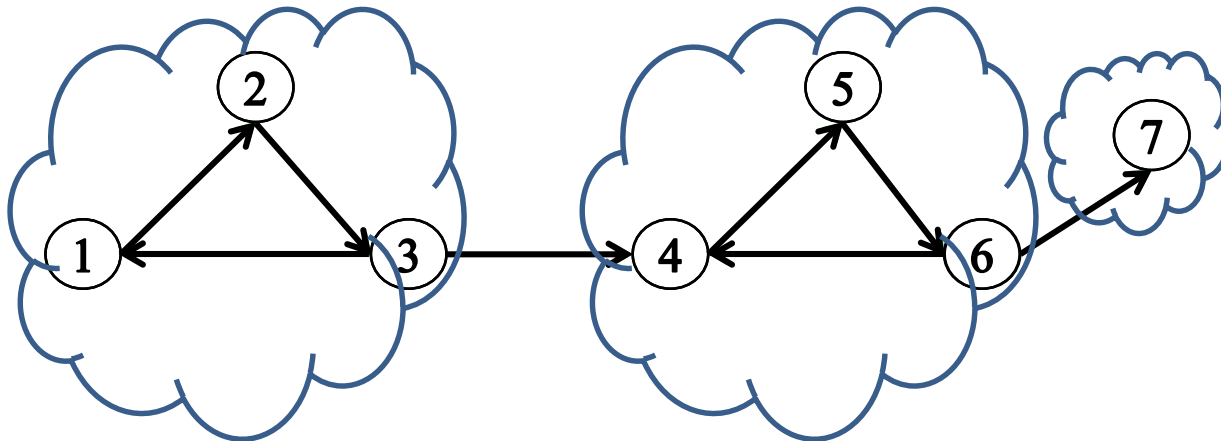

Path-Based Depth-First Search Algorithm

Algorithm 1 Path-Based Depth-First Search Algorithm

- 1: **Input:** A directed graph $G = (V, L)$
- 2: **Output:** Set of SCCs represented by SCC (initially empty)
- 3: **for** $v \in V$ **do**
- 4: Set the node as *unseen*.
- 5: Initiate a path $P = \{\}$
- 6: **for** $v \in V$ **do**
- 7: **if** v is *unseen* **then**
- 8: DFS(v).

Algorithm 2 DFS(v)

- 1: **if** v has no outgoing arc **then**
 - 2: Consider v as an SCC and add it to SCC
 - 3: Set v as *seen*.
 - 4: Remove it from P .
 - 5: **else**
 - 6: **for** arc $(v, w) \in E$ **do**
 - 7: **if** $w \in P$ ($v_i = w$) **then**
 - 8: Contract the nodes $v_i, v_{i+1}, \dots, v_{|P|}$.
 - 9: **else**
 - 10: Add w to P .
 - 11: Set w as *seen*.
 - 12: DFS(w).
-

Path-Based Depth-First Search Alg.

SCCs

P

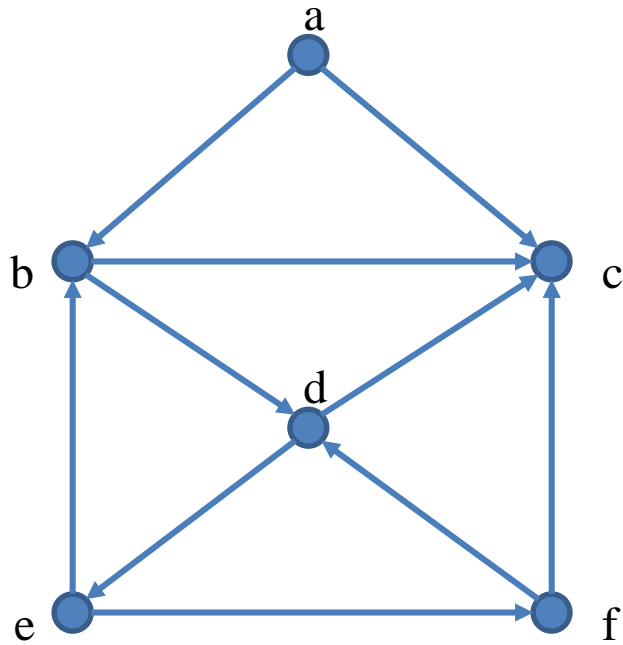

Path-Based Depth-First Search Alg.

SCCs

P

a ●

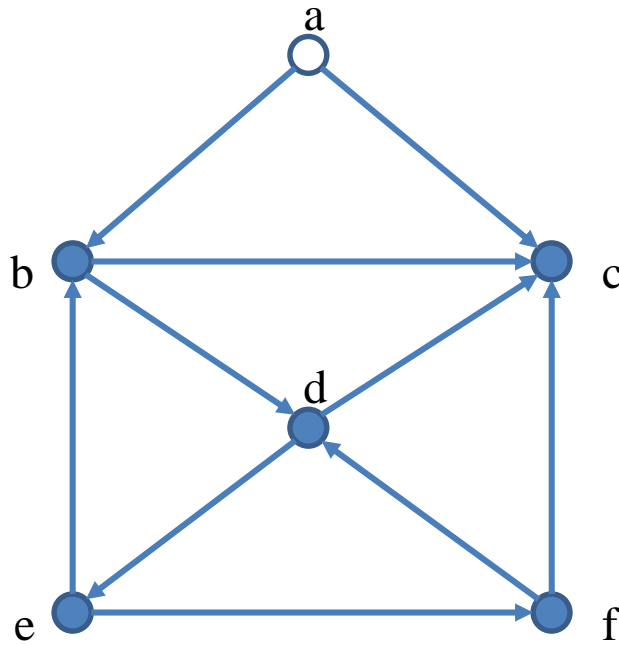

Path-Based Depth-First Search Alg.

SCCs

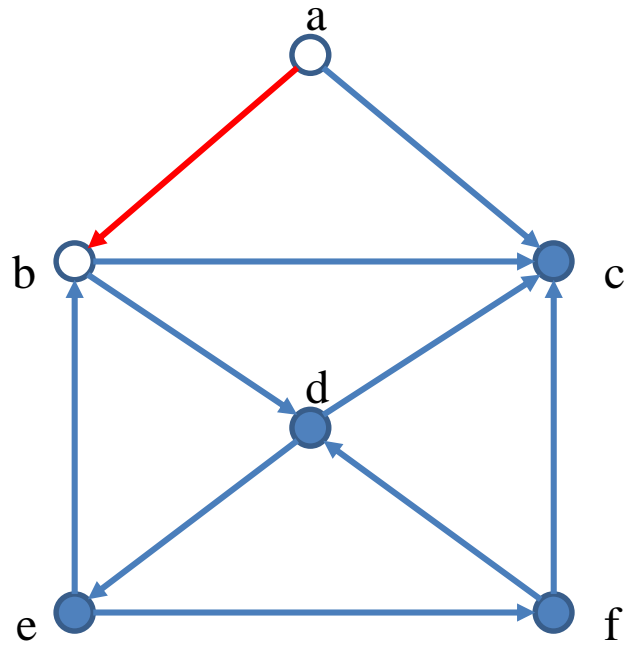

P

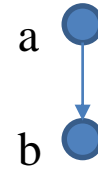

Path-Based Depth-First Search Alg.

SCCs

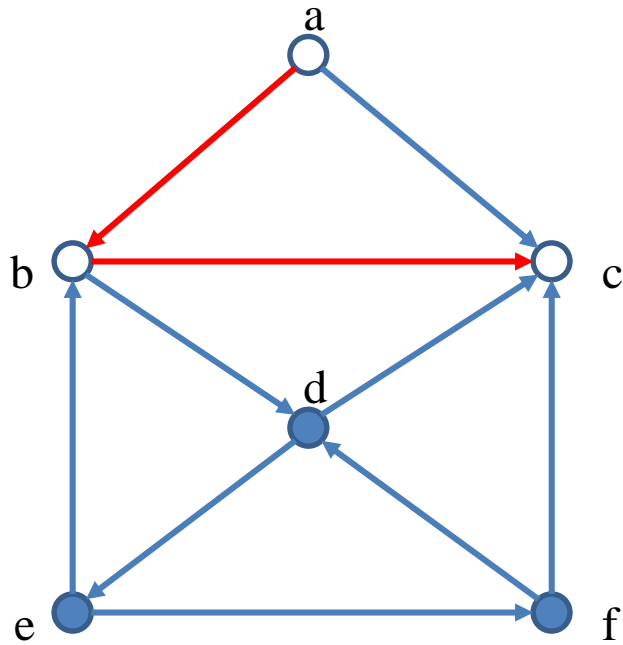

P

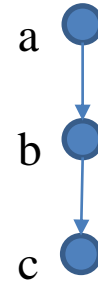

Path-Based Depth-First Search Alg.

SCCs

{c}

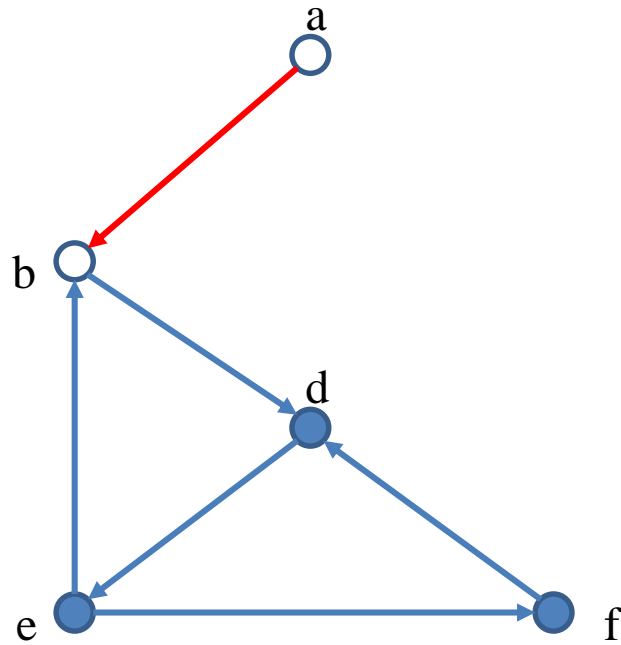

P



Path-Based Depth-First Search Alg.

SCCs

{c}

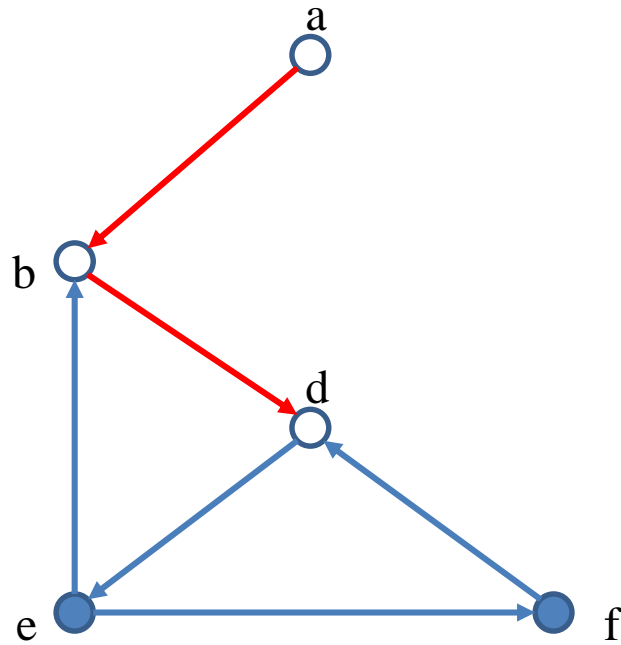

P

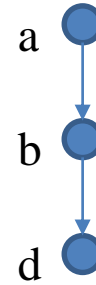

Path-Based Depth-First Search Alg.

SCCs

{c}

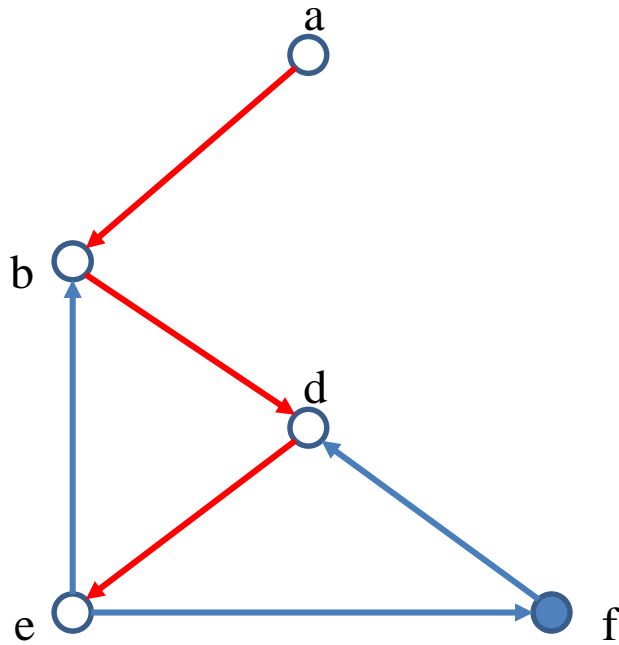

P



Path-Based Depth-First Search Alg.

SCCs

{c}

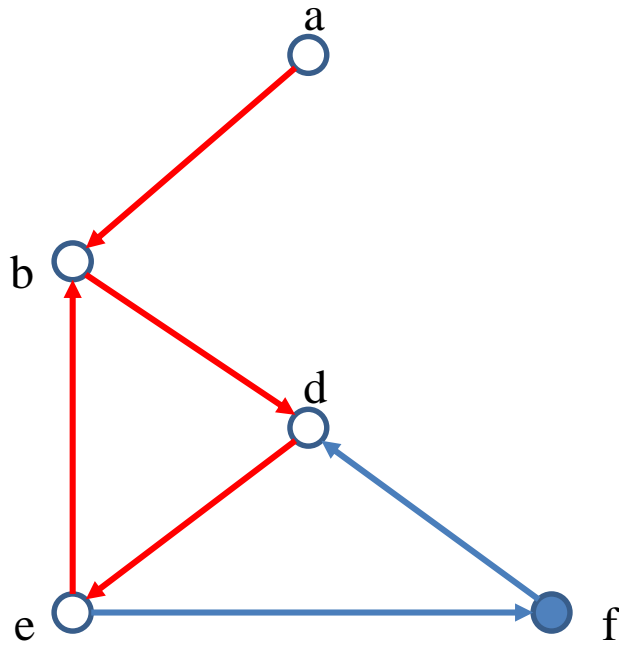

P

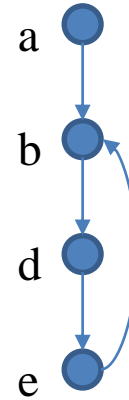

Path-Based Depth-First Search Alg.

SCCs

{c}

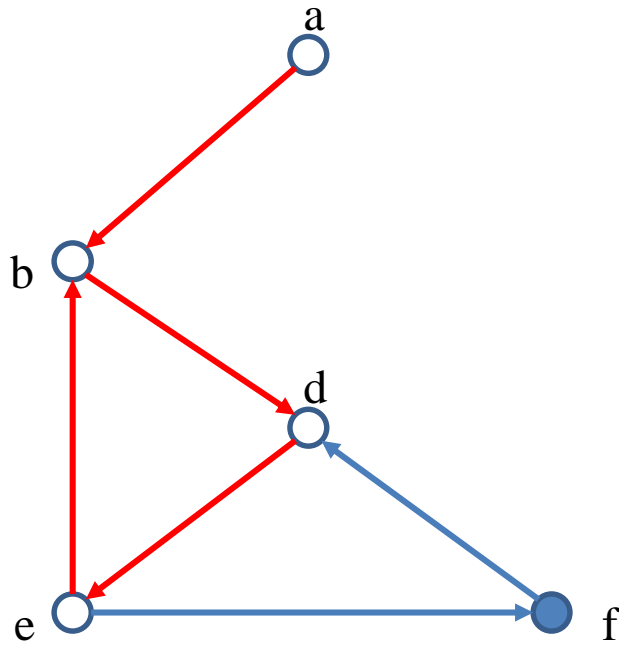

P

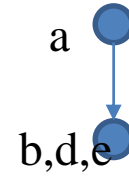

Path-Based Depth-First Search Alg.

SCCs

{c}

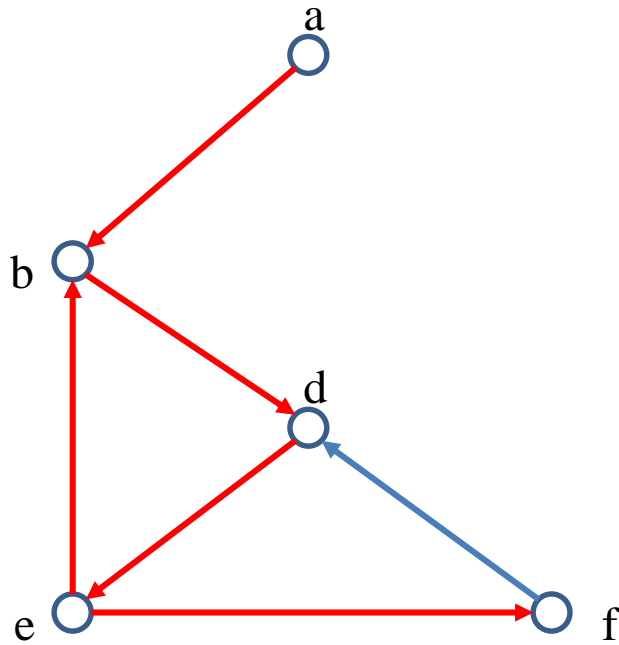

P

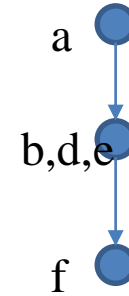

Path-Based Depth-First Search Alg.

SCCs

{c}

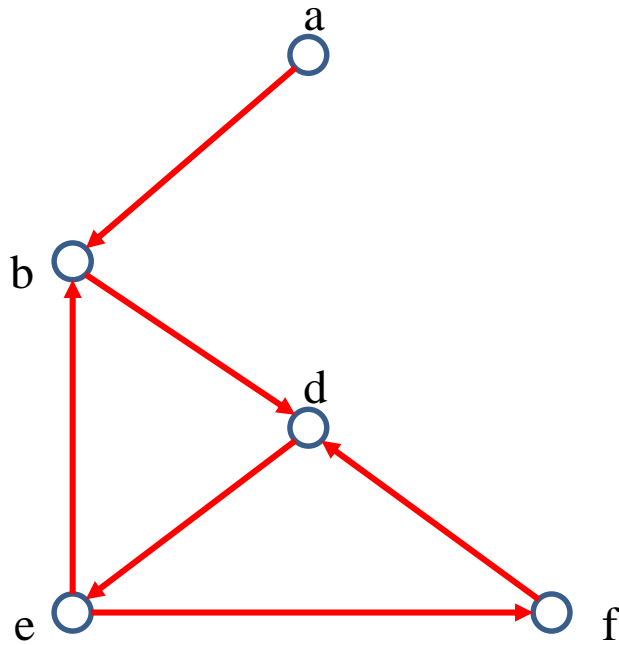

P

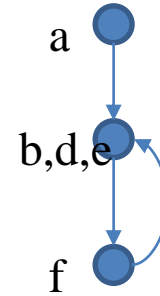

Path-Based Depth-First Search Alg.

SCCs

{c}

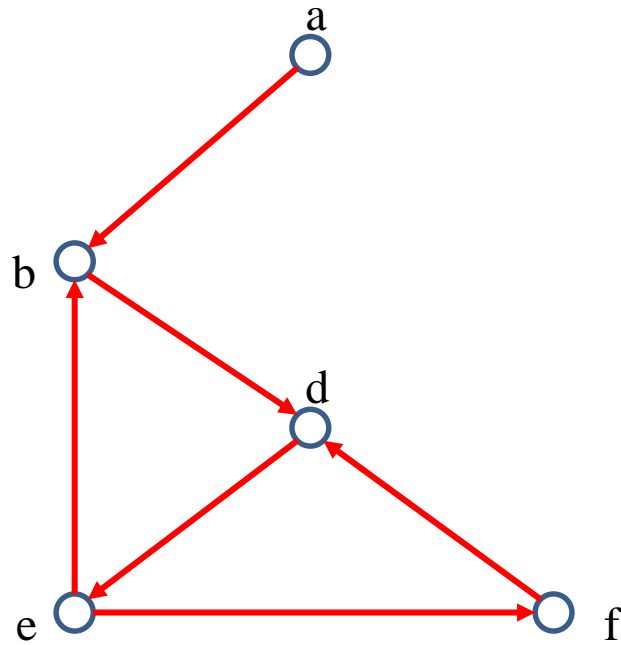

P

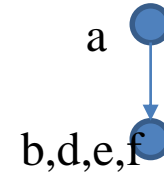

Path-Based Depth-First Search Alg.

SCCs

{c}

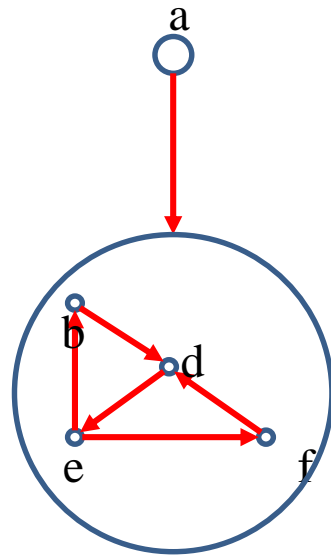

P

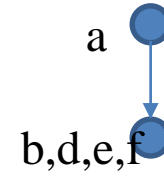

Path-Based Depth-First Search Alg.

SCCs

{c}
{b,d,e,f}

a



P

a 

Path-Based Depth-First Search Alg.

SCCs

{c}
{b,d,e,f}
{a}

a 

P

a 

Path-Based Depth-First Search Alg.

SCCs

P

{c}

{b,d,e,f}

{a}

Complexity

$$O(E + V)$$

Kosaraju-Sharir algorithm

Algorithm 3 Kosaraju-Sharir Algorithm

- 1: **Input:** A directed graph $G = (V, L)$
 - 2: **Output:** Set of SCCs represented by SCC (initially empty)
 - 3: Run DFS on Graph G to compute finishing time (reverse postorder) of each node.
 - 4: $V^R = V, L^R = \emptyset$.
 - 5: Build $G^R = (V^R, L^R)$
 - 6: **for** $l = (u, v) \in L$ **do**
 - 7: $L^R = L^R \cup (v, u)$
 - 8: Run DFS on G^R , considering vertices in the decreasing reverse postorder.
 - 9: Output the vertices of each Depth First Traversal as an SCC.
-

Kosaraju-Sharir algorithm [2]

0 - Seen, not finished yet.

0 - Finished.

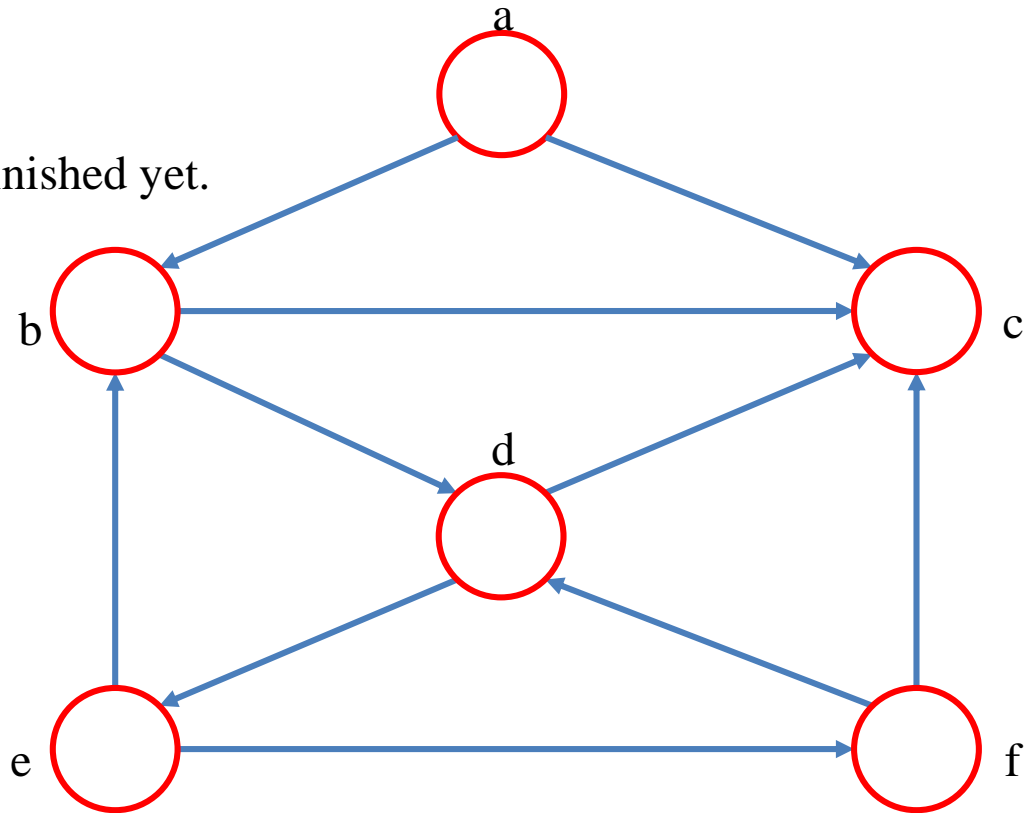

Kosaraju-Sharir algorithm [2]

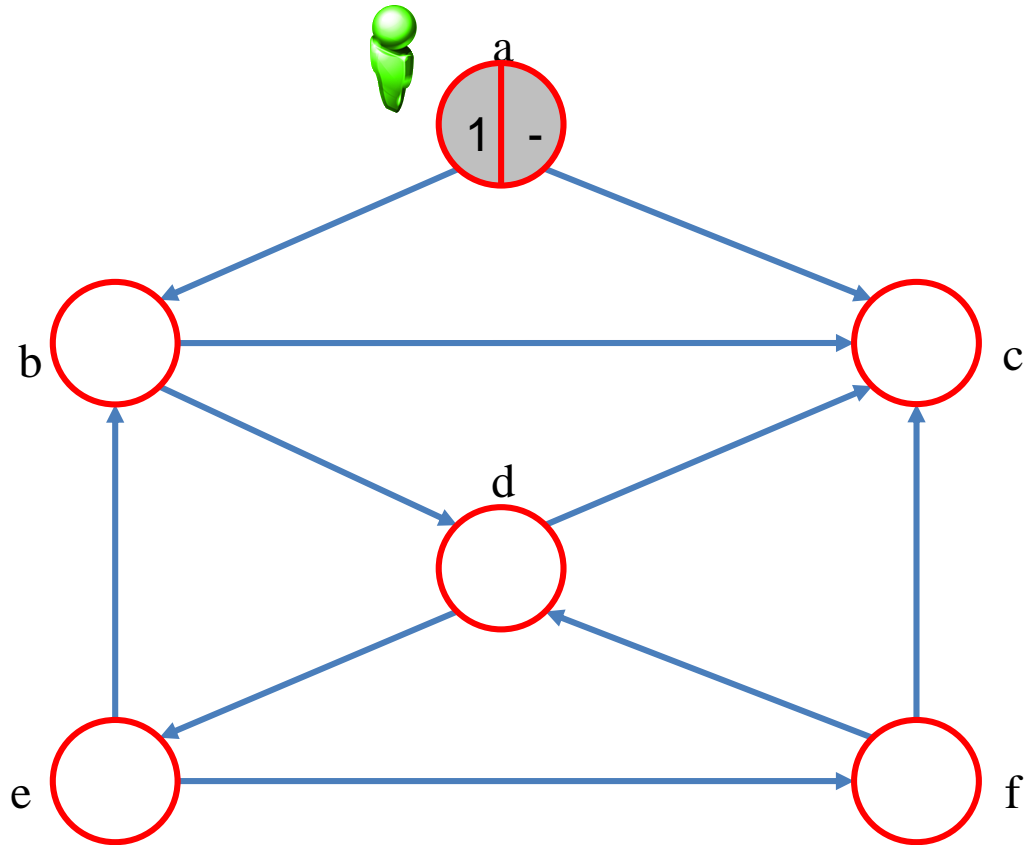

Kosaraju-Sharir algorithm [2]

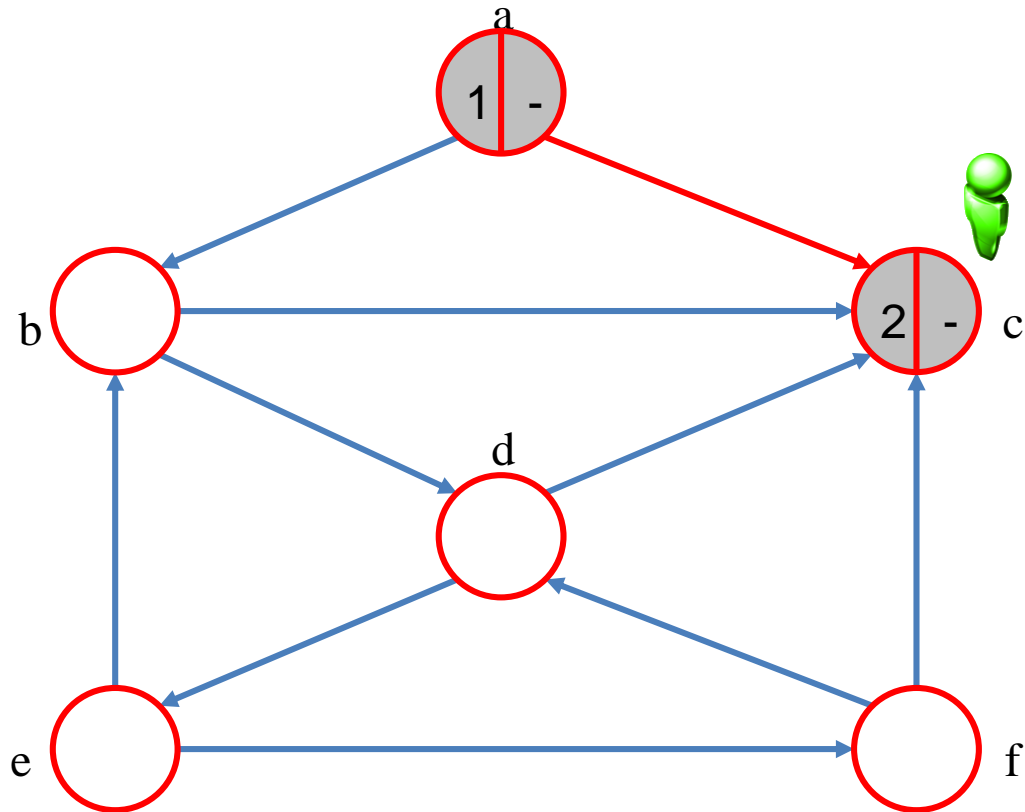

Kosaraju-Sharir algorithm [2]

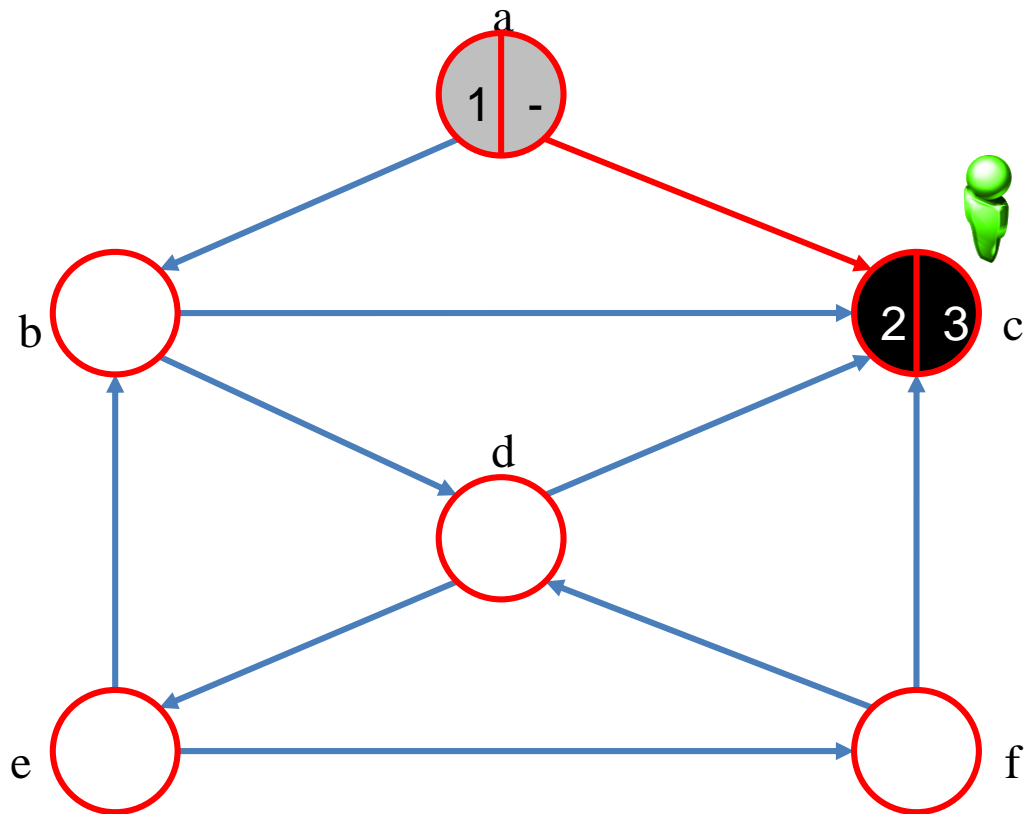

Kosaraju-Sharir algorithm [2]

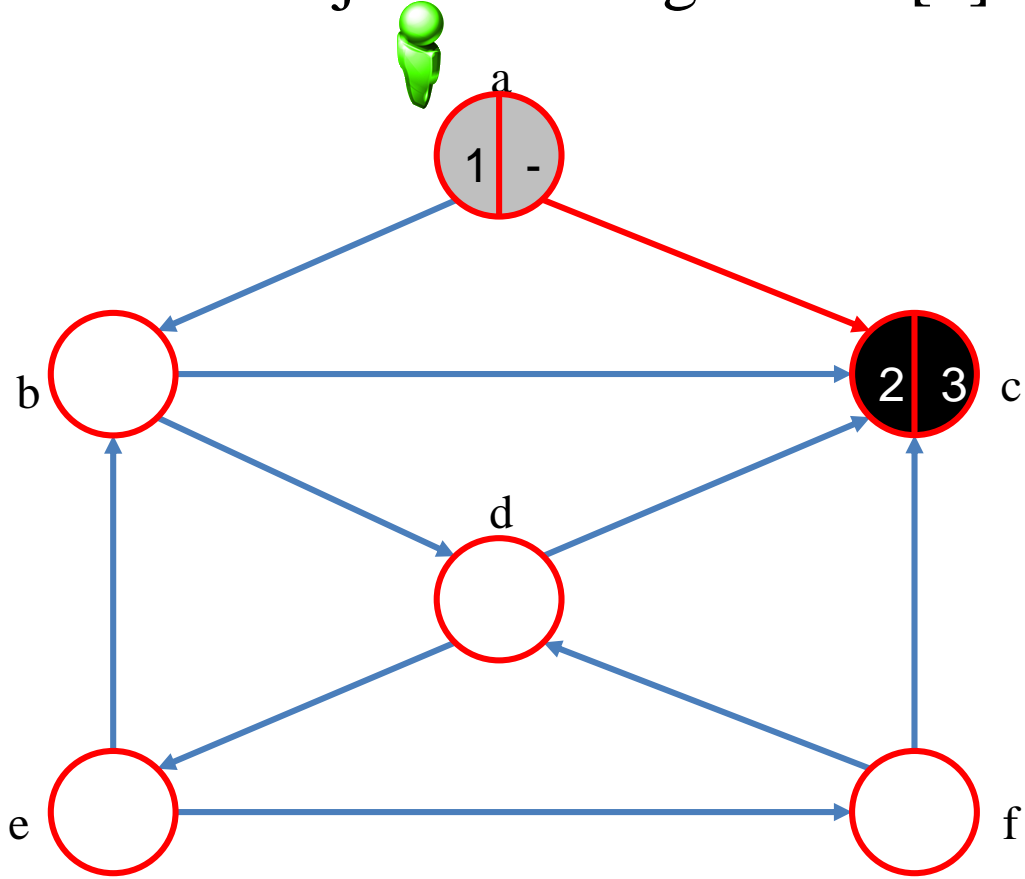

Kosaraju-Sharir algorithm [2]

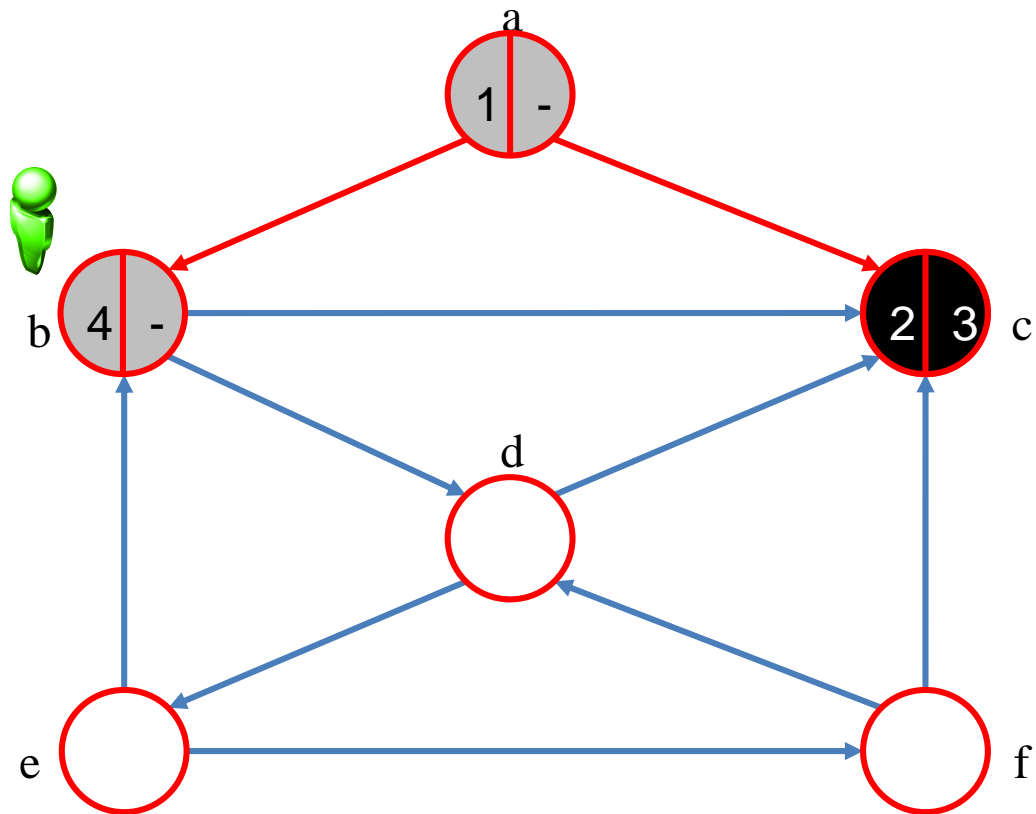

Kosaraju-Sharir algorithm [2]

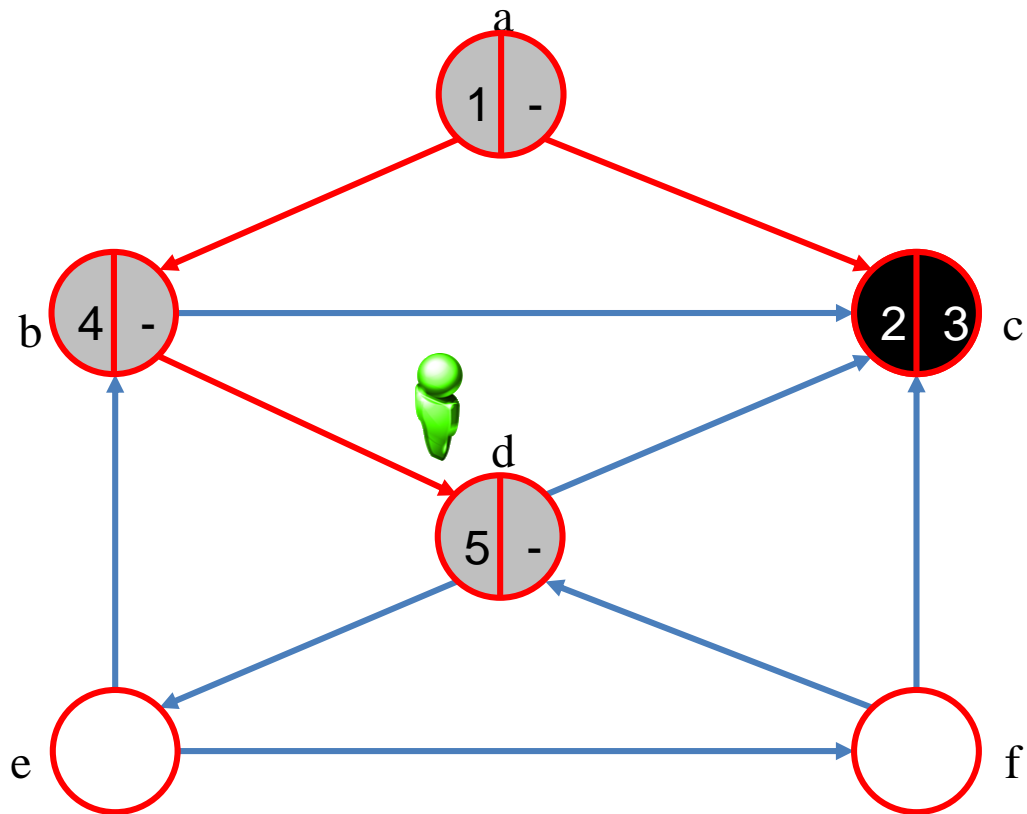

Kosaraju-Sharir algorithm [2]

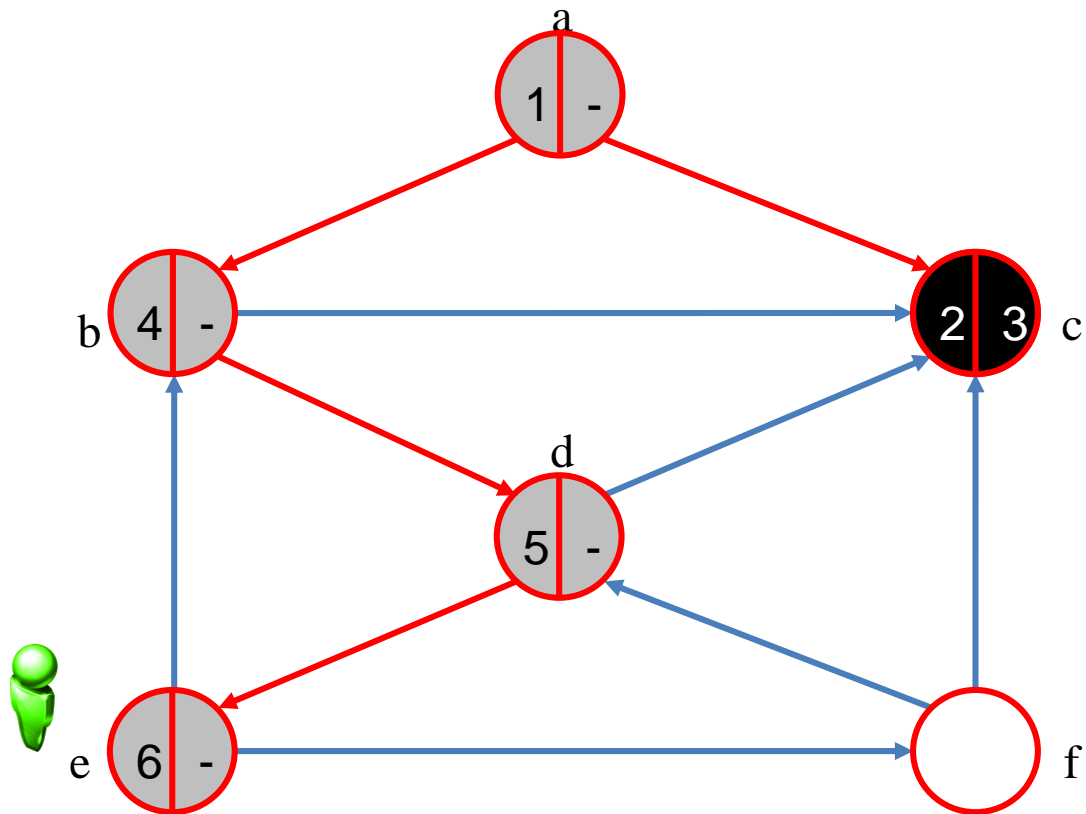

Kosaraju-Sharir algorithm [2]

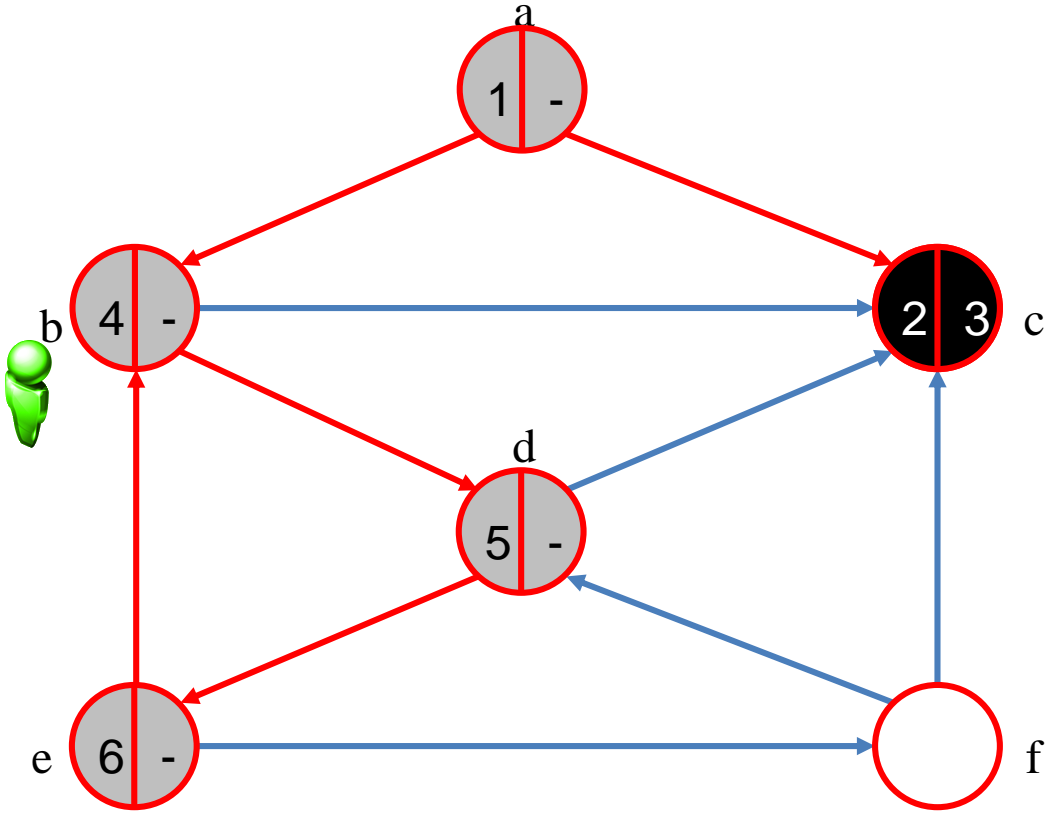

Kosaraju-Sharir algorithm [2]

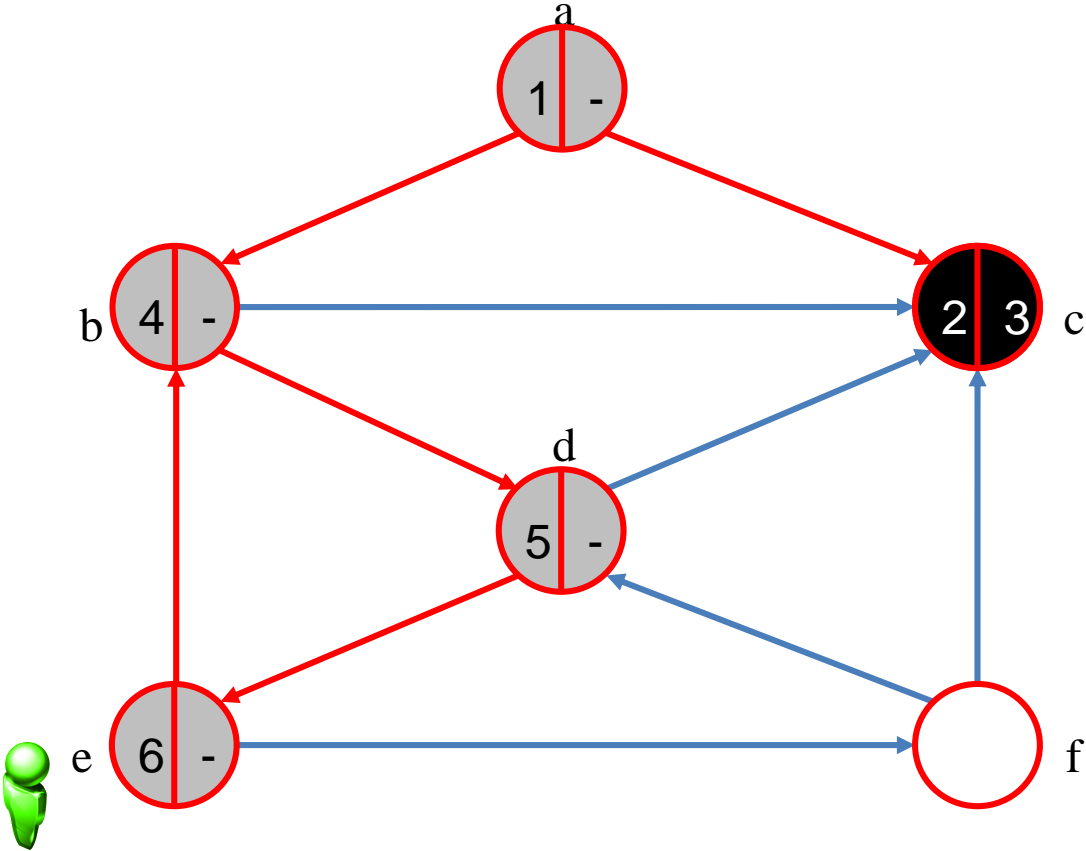

Kosaraju-Sharir algorithm [2]

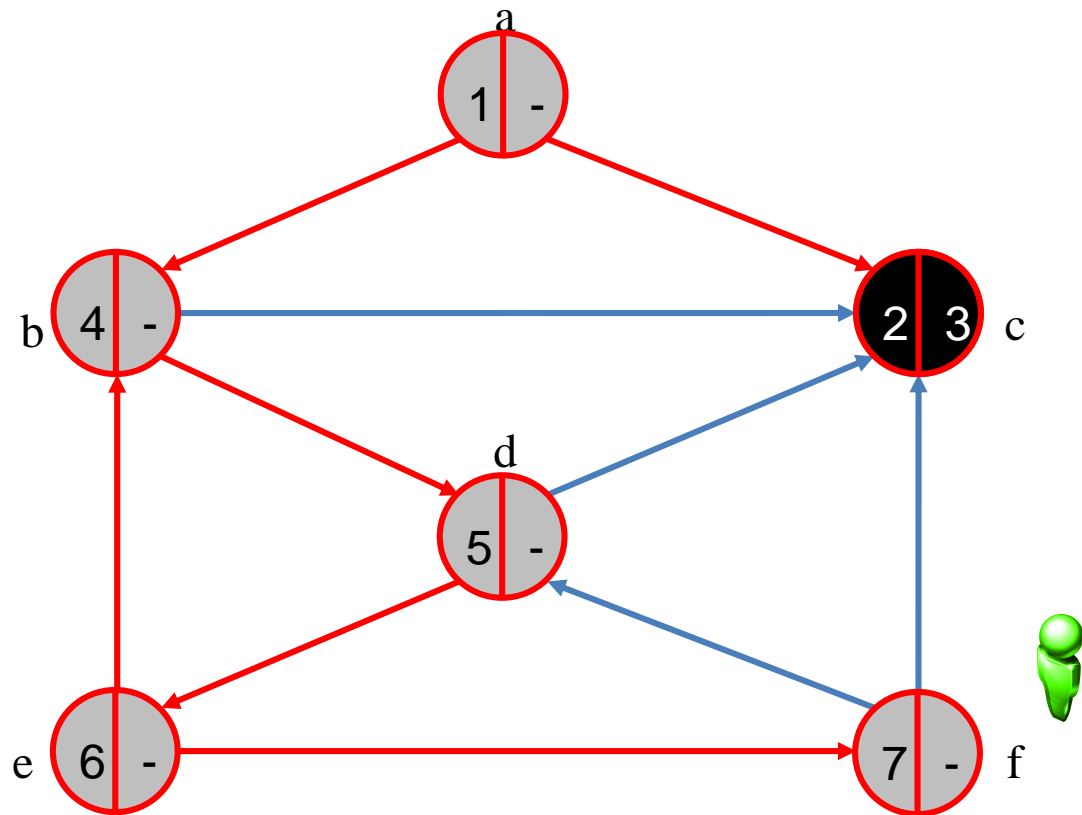

Kosaraju-Sharir algorithm [2]

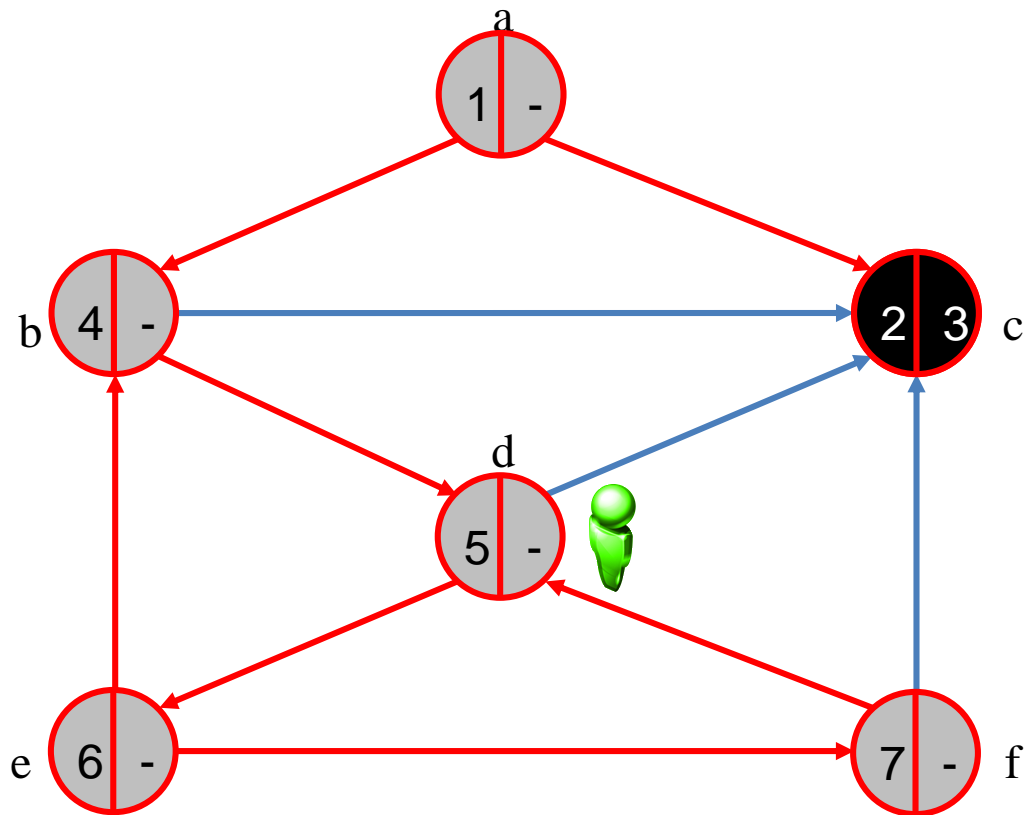

Kosaraju-Sharir algorithm [2]

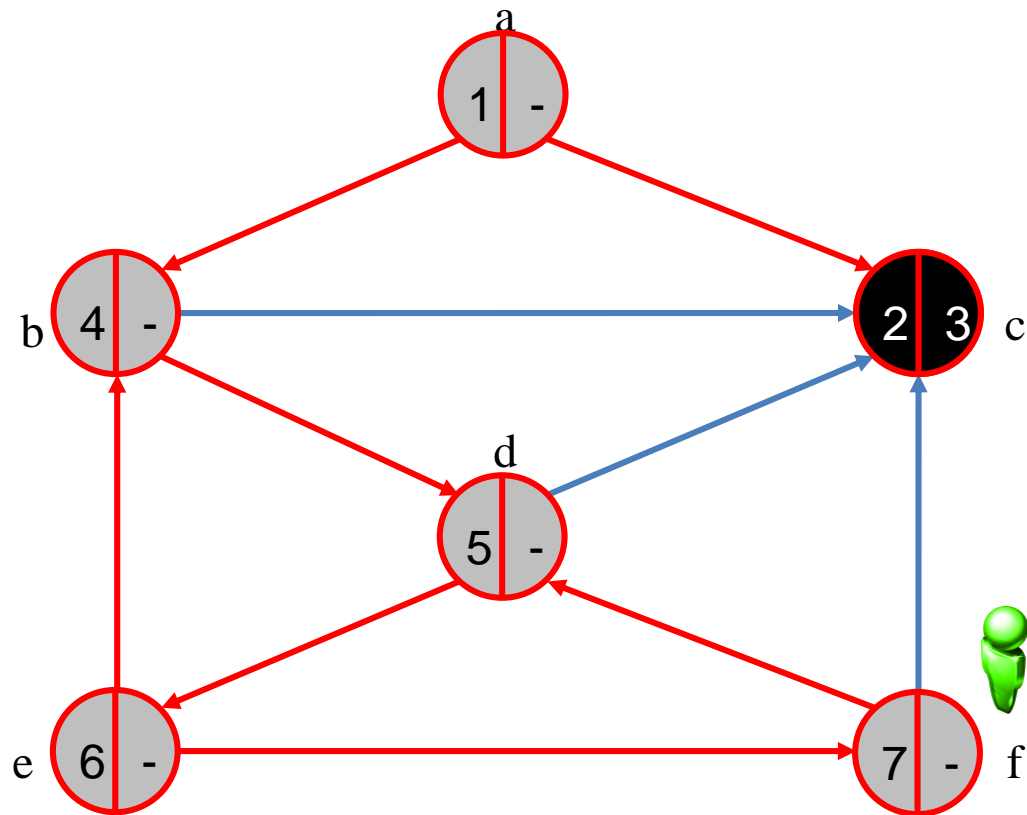

Kosaraju-Sharir algorithm [2]

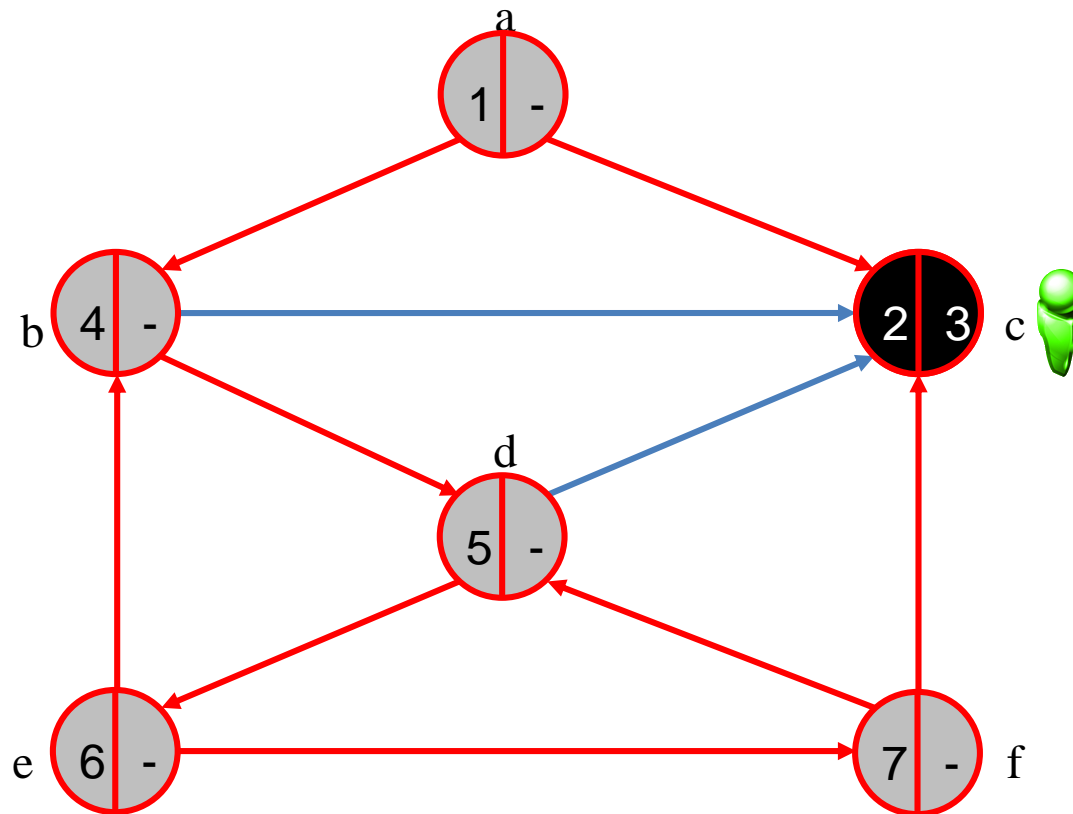

Kosaraju-Sharir algorithm [2]

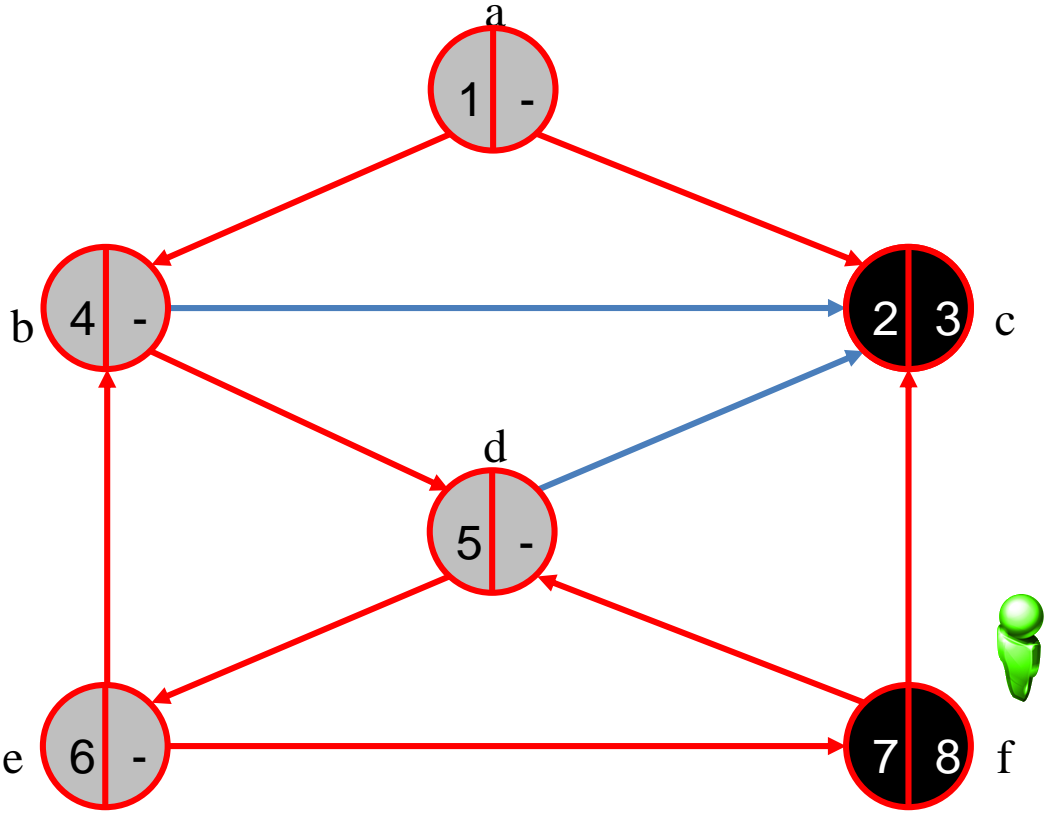

Kosaraju-Sharir algorithm [2]

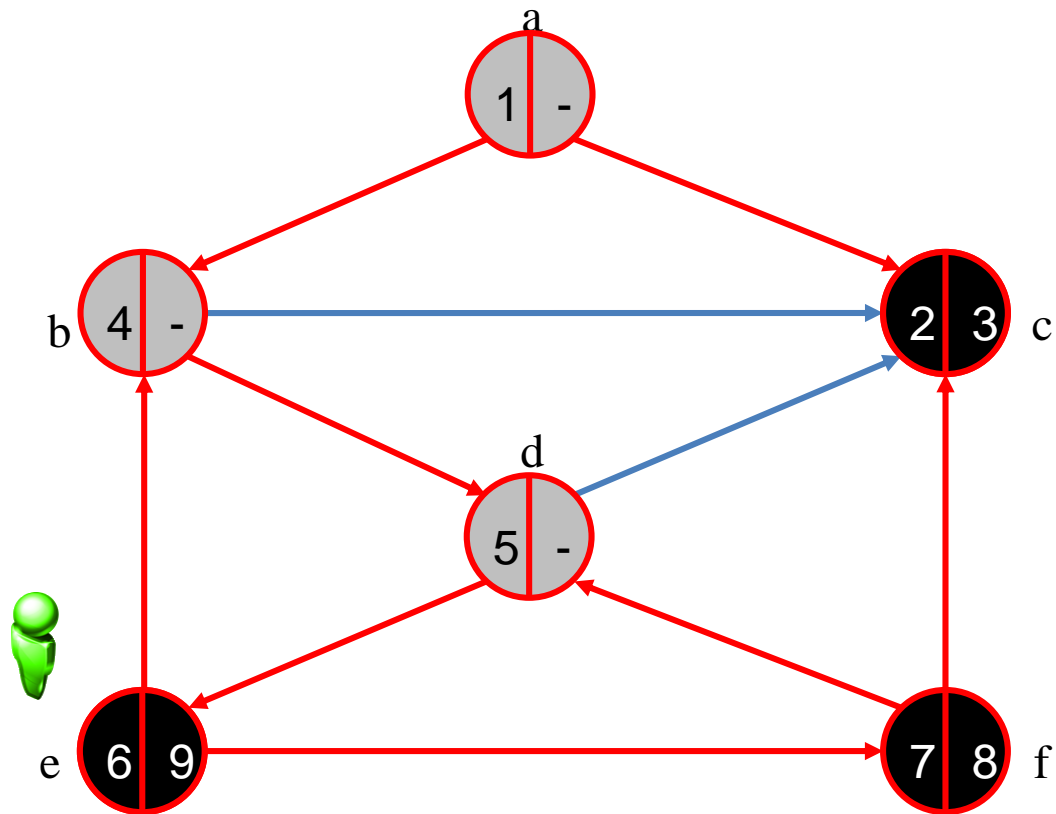

Kosaraju-Sharir algorithm [2]

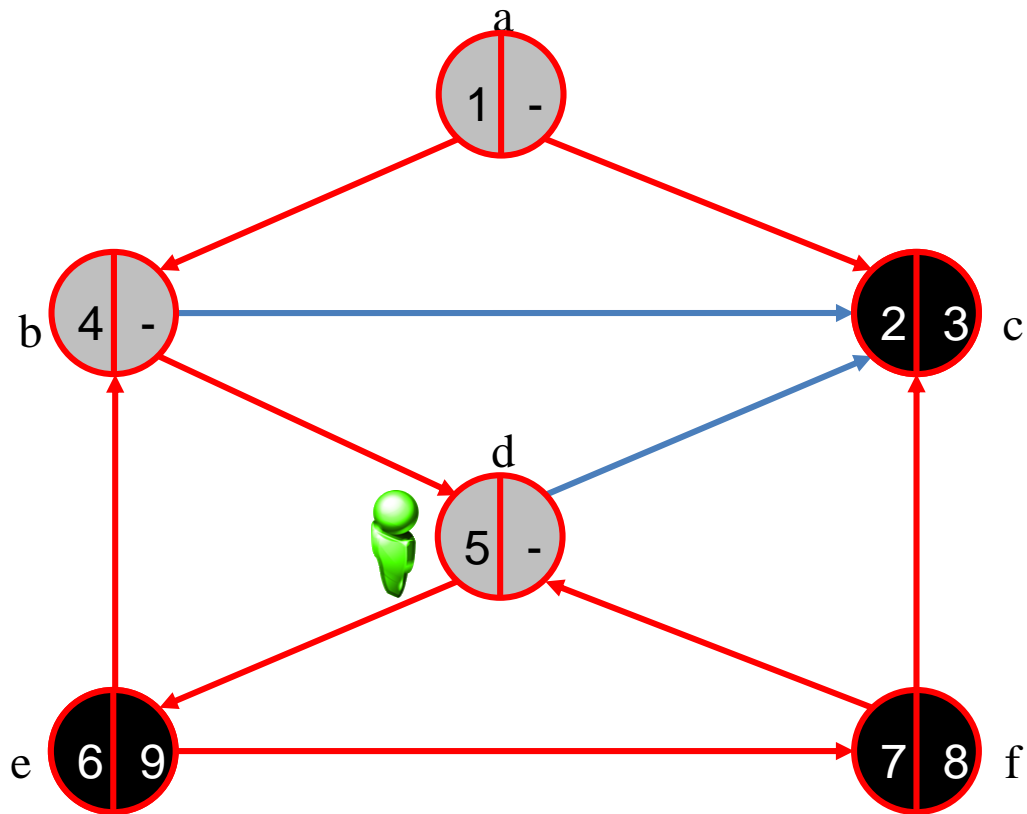

Kosaraju-Sharir algorithm [2]

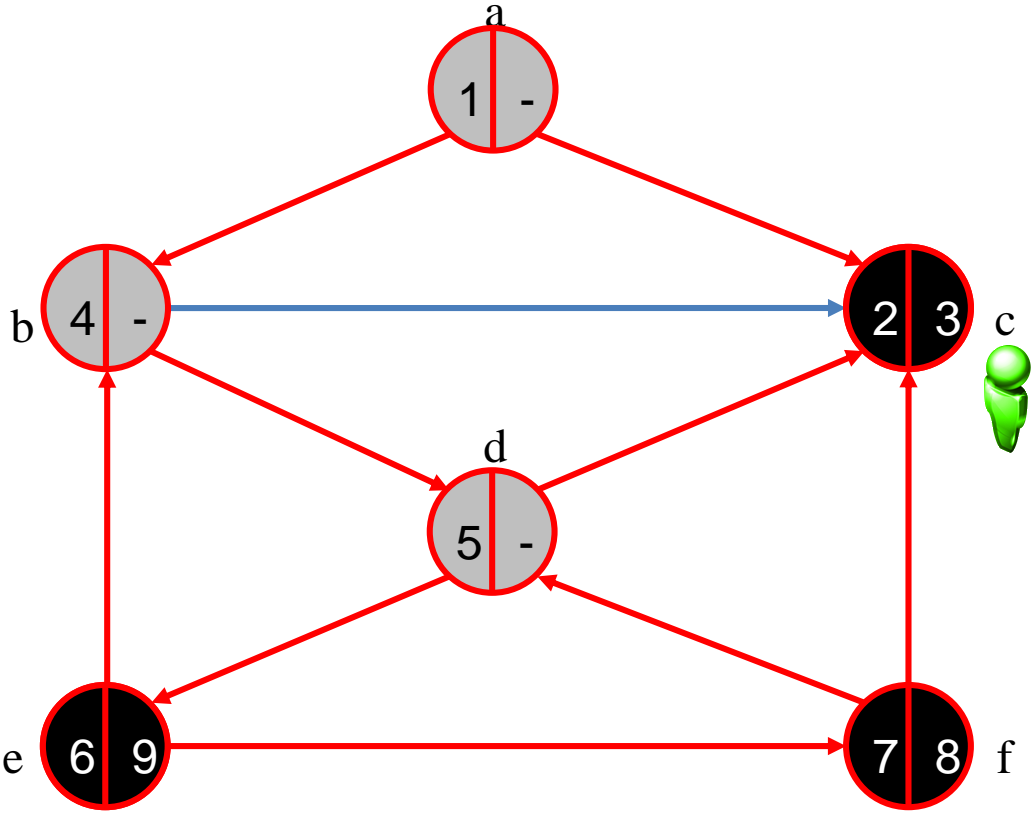

Kosaraju-Sharir algorithm [2]

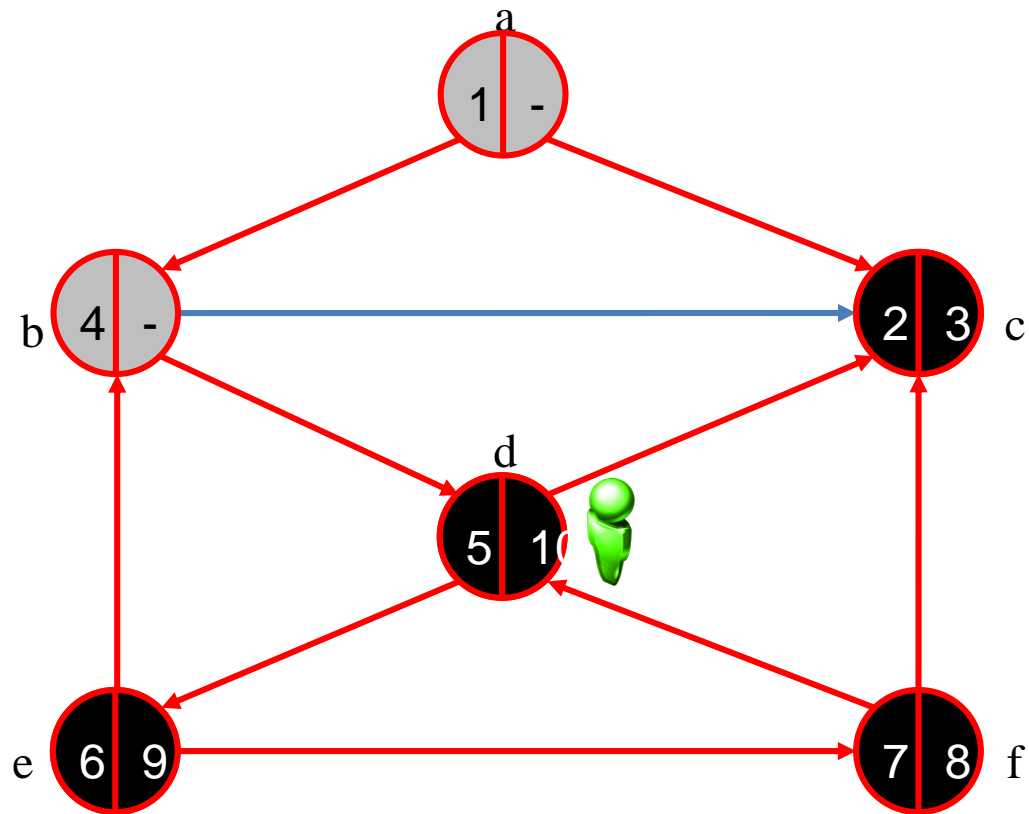

Kosaraju-Sharir algorithm [2]

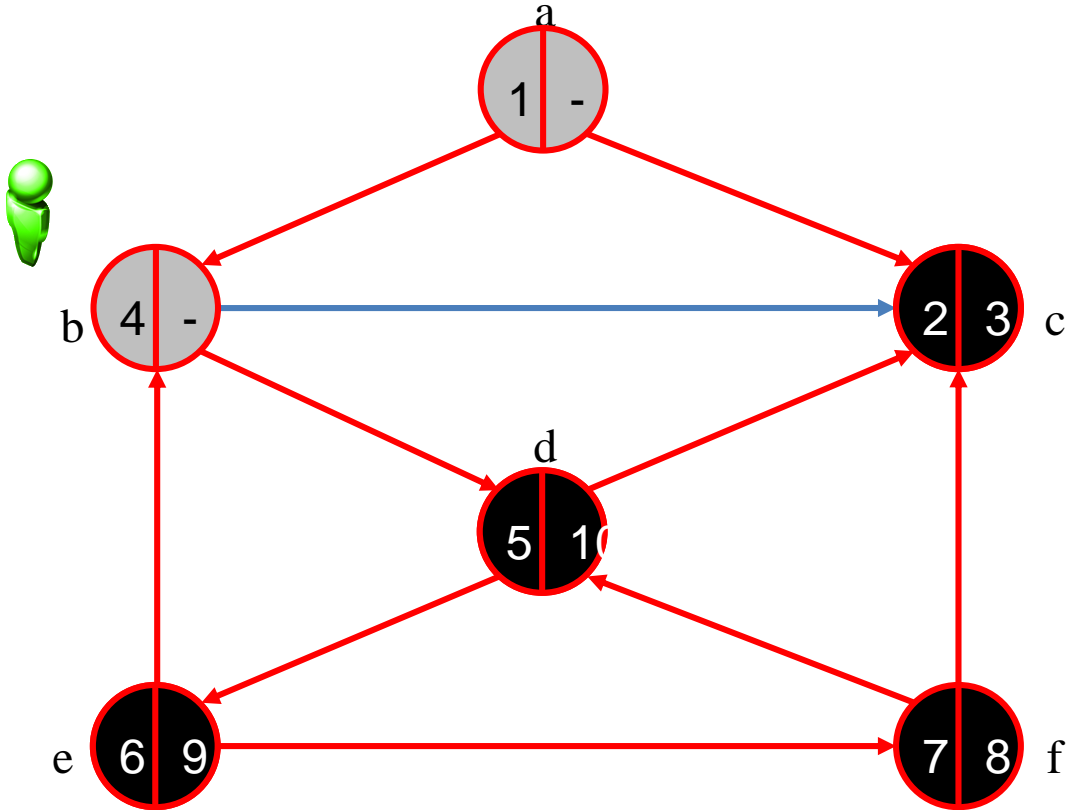

Kosaraju-Sharir algorithm [2]

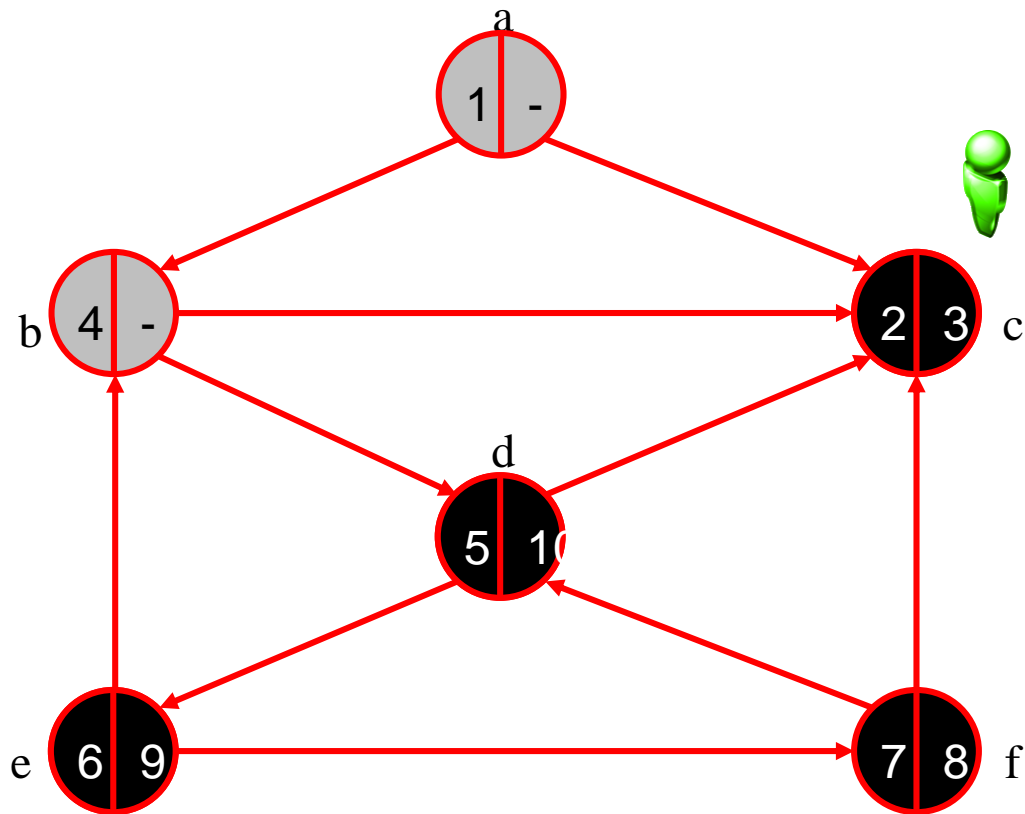

Kosaraju-Sharir algorithm [2]

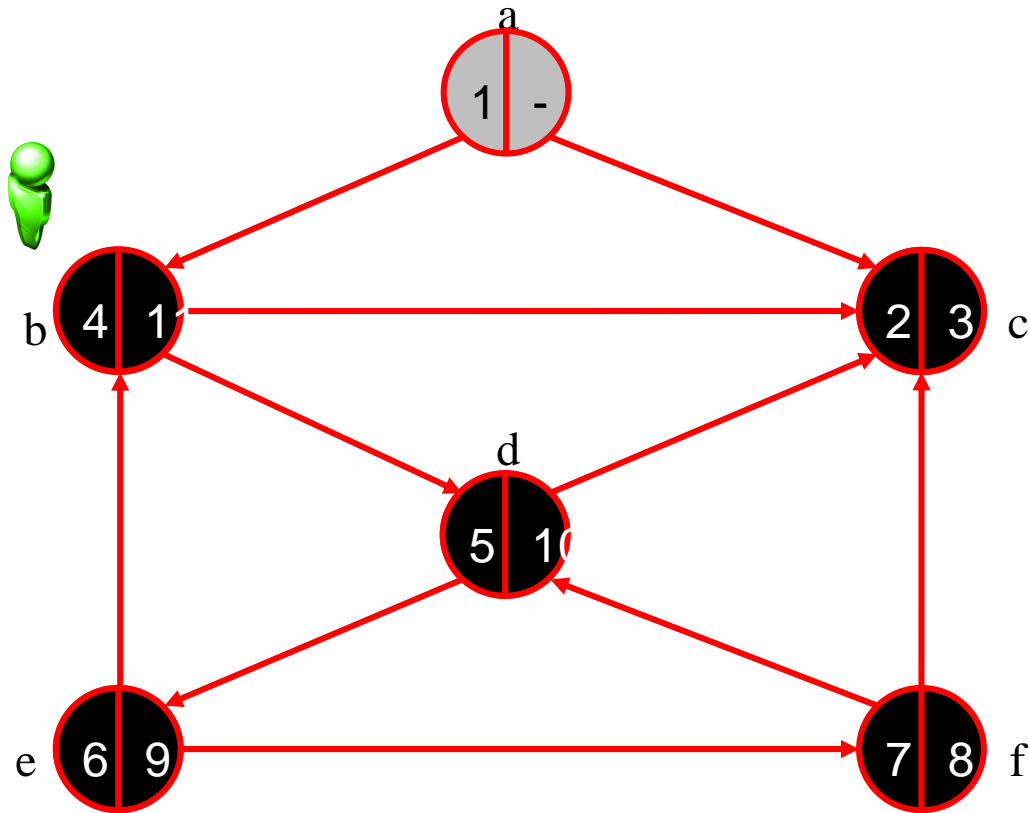

Kosaraju-Sharir algorithm [2]

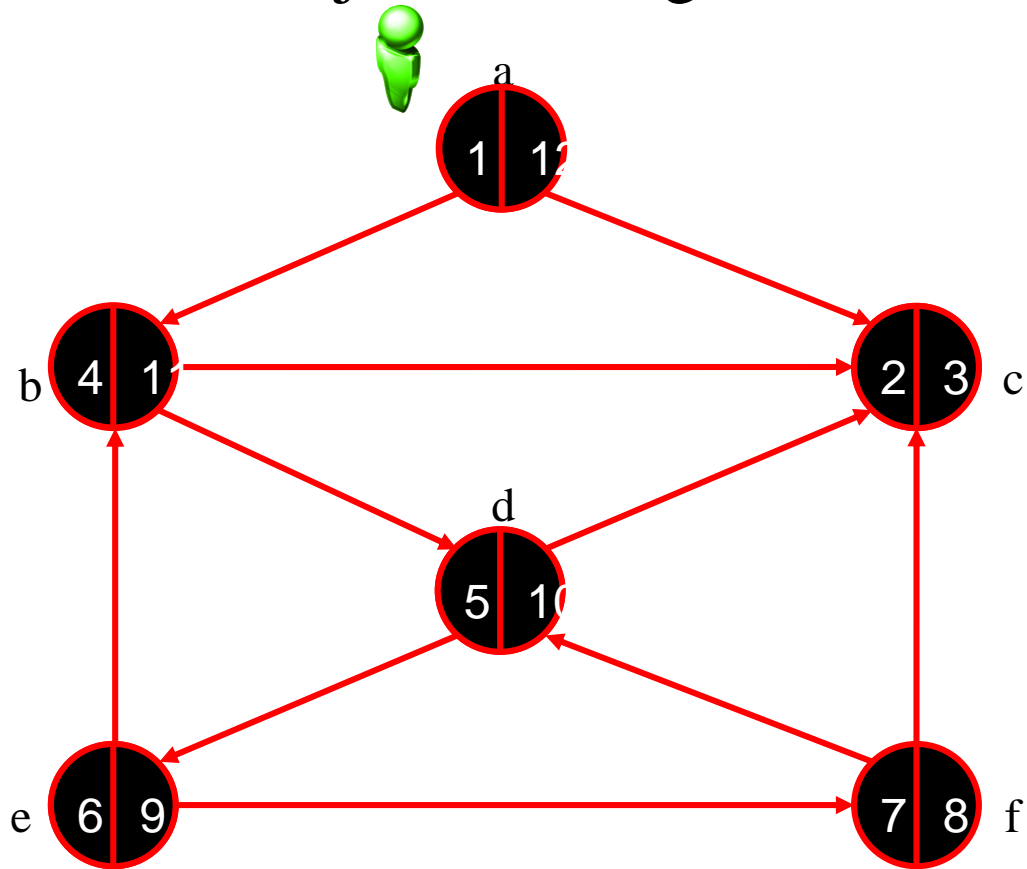

Kosaraju-Sharir algorithm

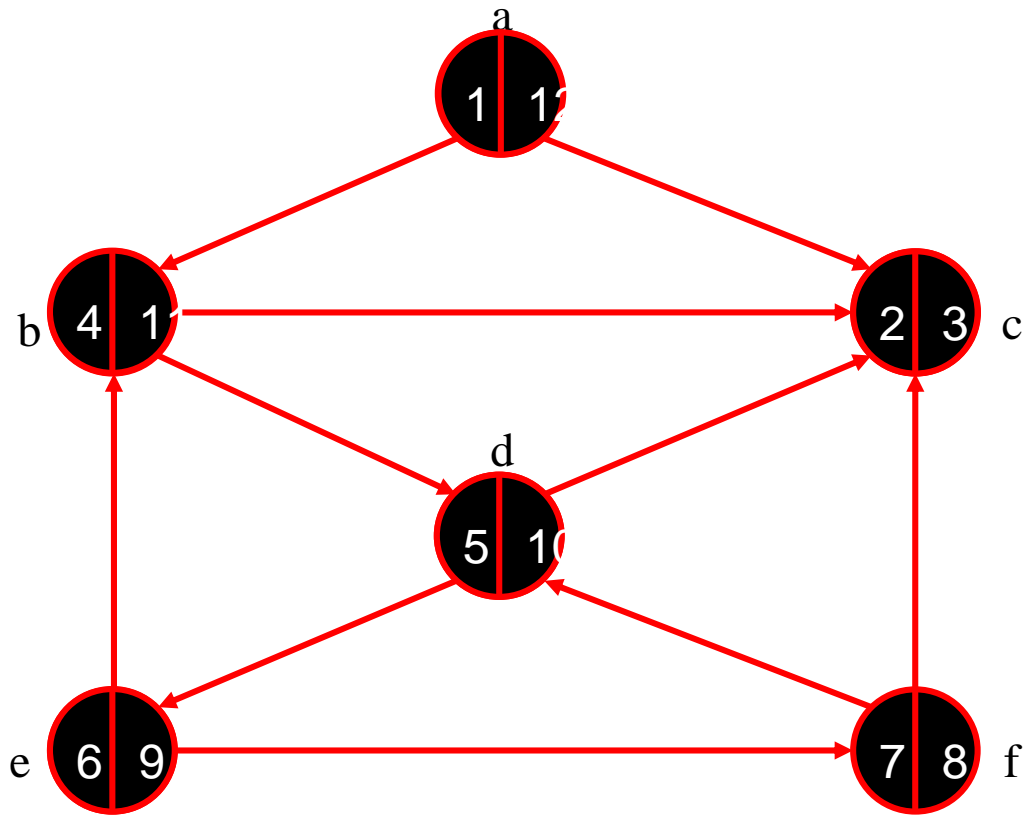

$\{a, b, d, e, f, c\}$

Kosaraju-Sharir algorithm [2]

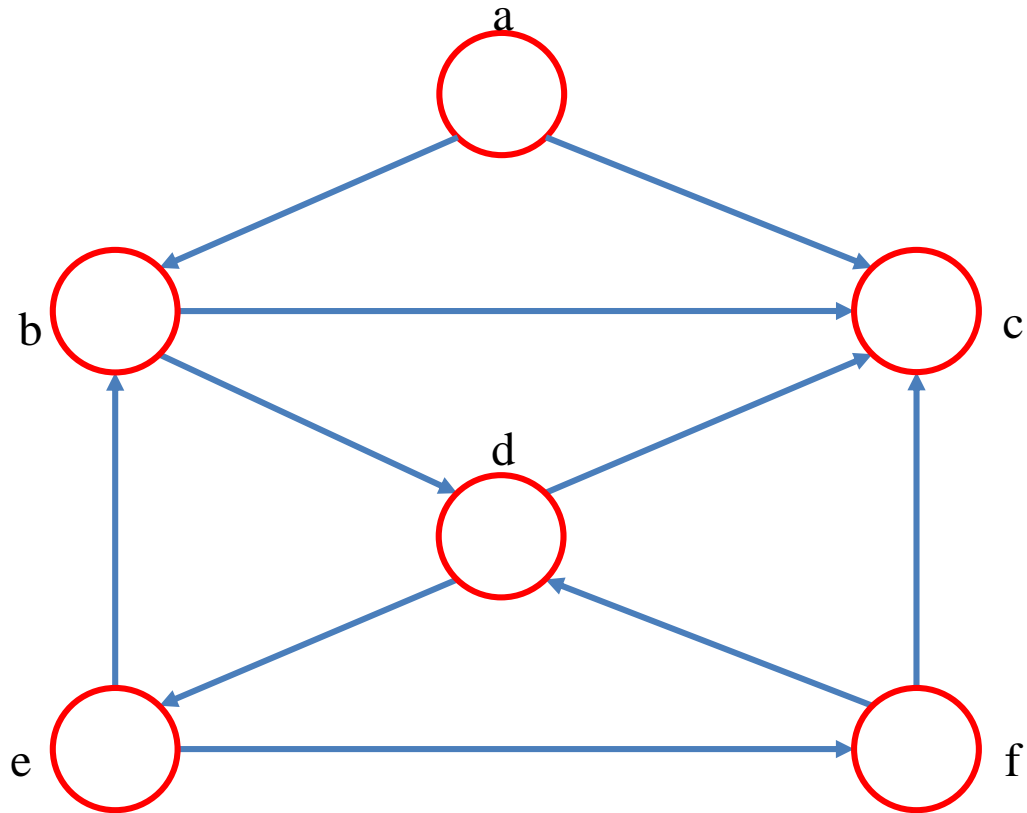

Kosaraju-Sharir algorithm [2]

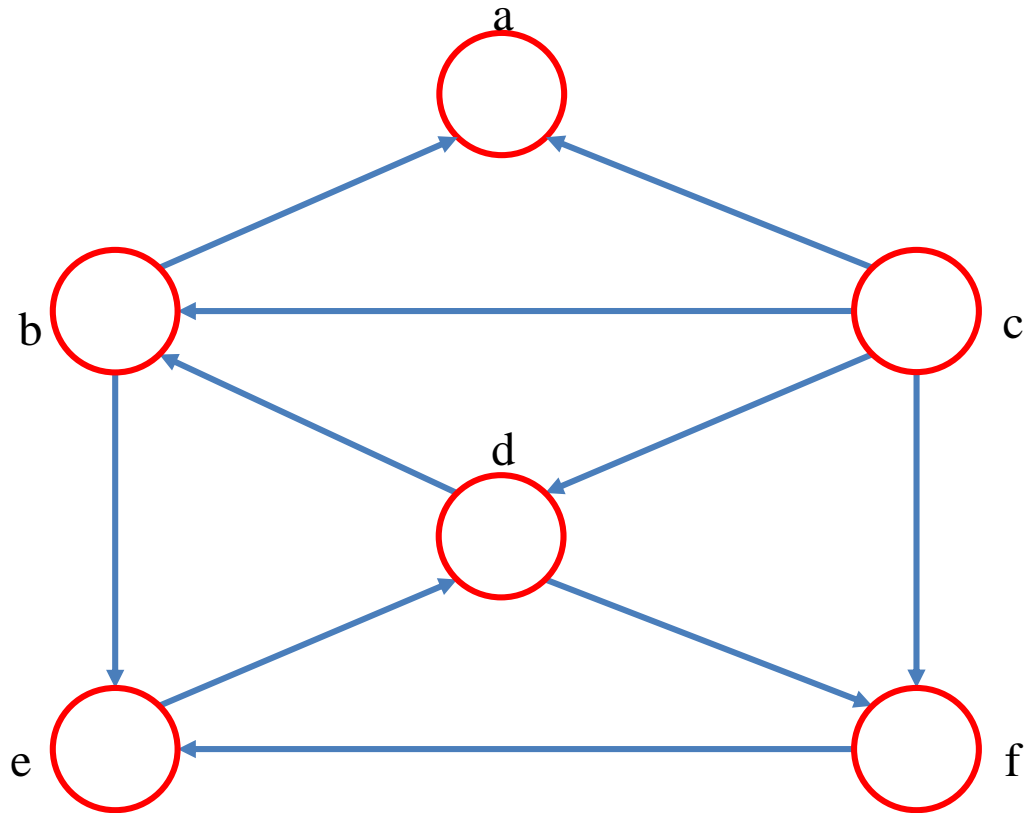

Kosaraju-Sharir algorithm [2]

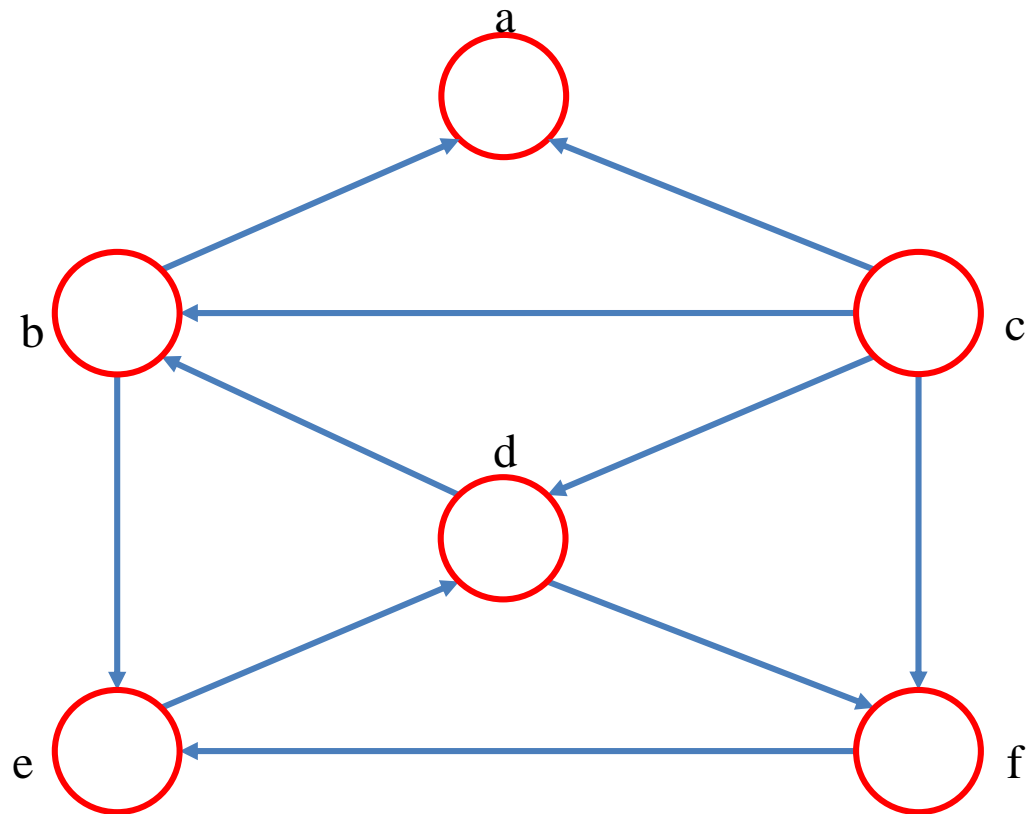

$\{a, b, d, e, f, c\}$

Kosaraju-Sharir algorithm [2]

SCCs

{a}

{a, b, d, e, f, c}

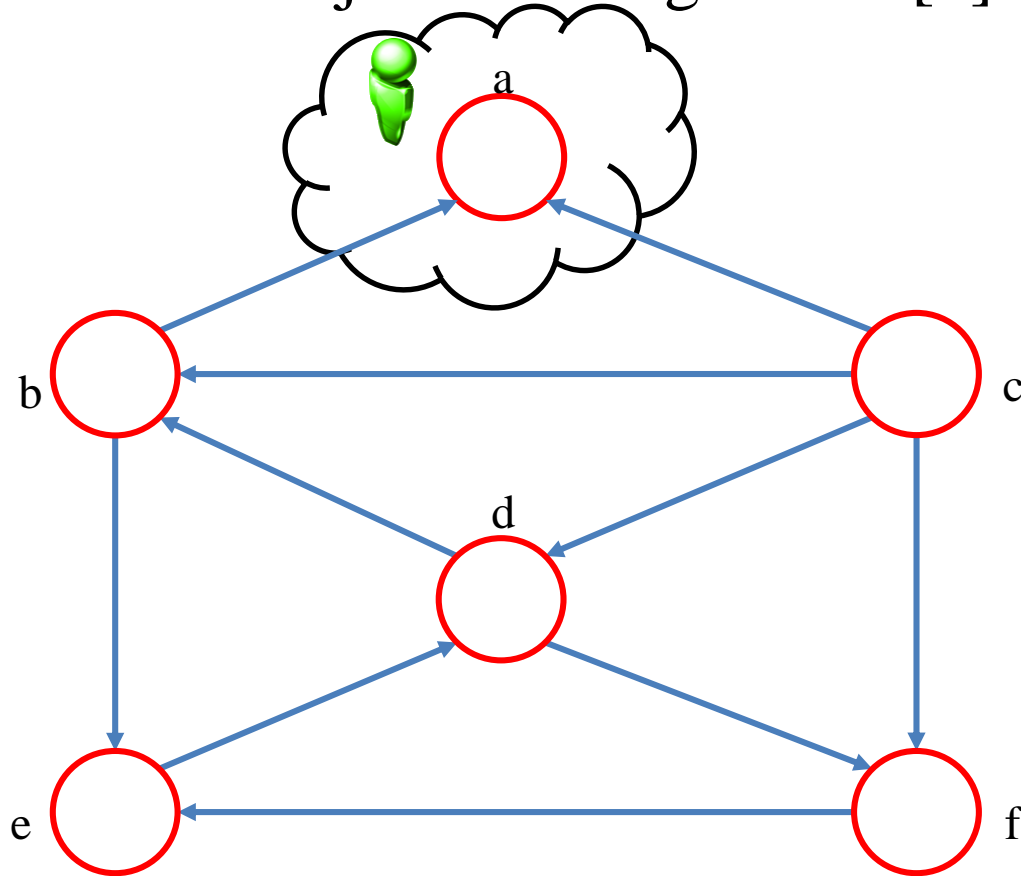

Kosaraju-Sharir algorithm [2]

SCCs

{a}

{a, b, d, e, f, c}

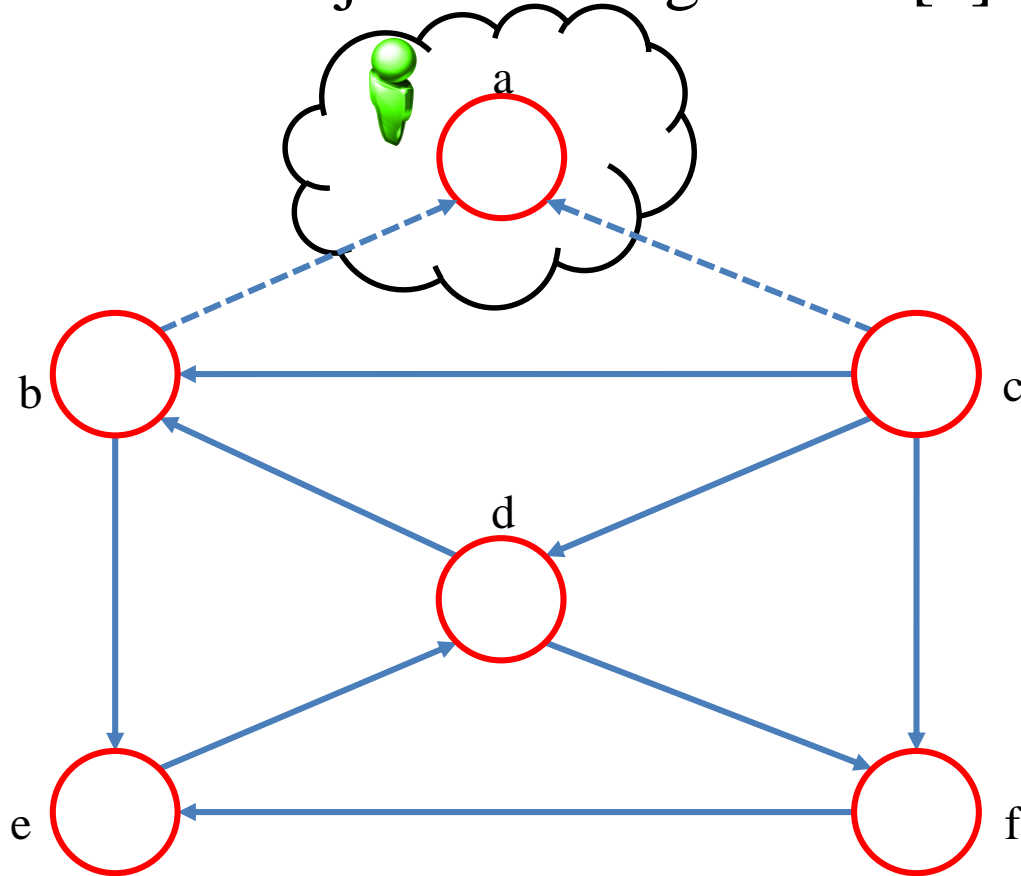

Kosaraju-Sharir algorithm [2]

SCCs

$\{a\}$
 $\{b, d, e, f\}$

$\{a, b, d, e, f, c\}$

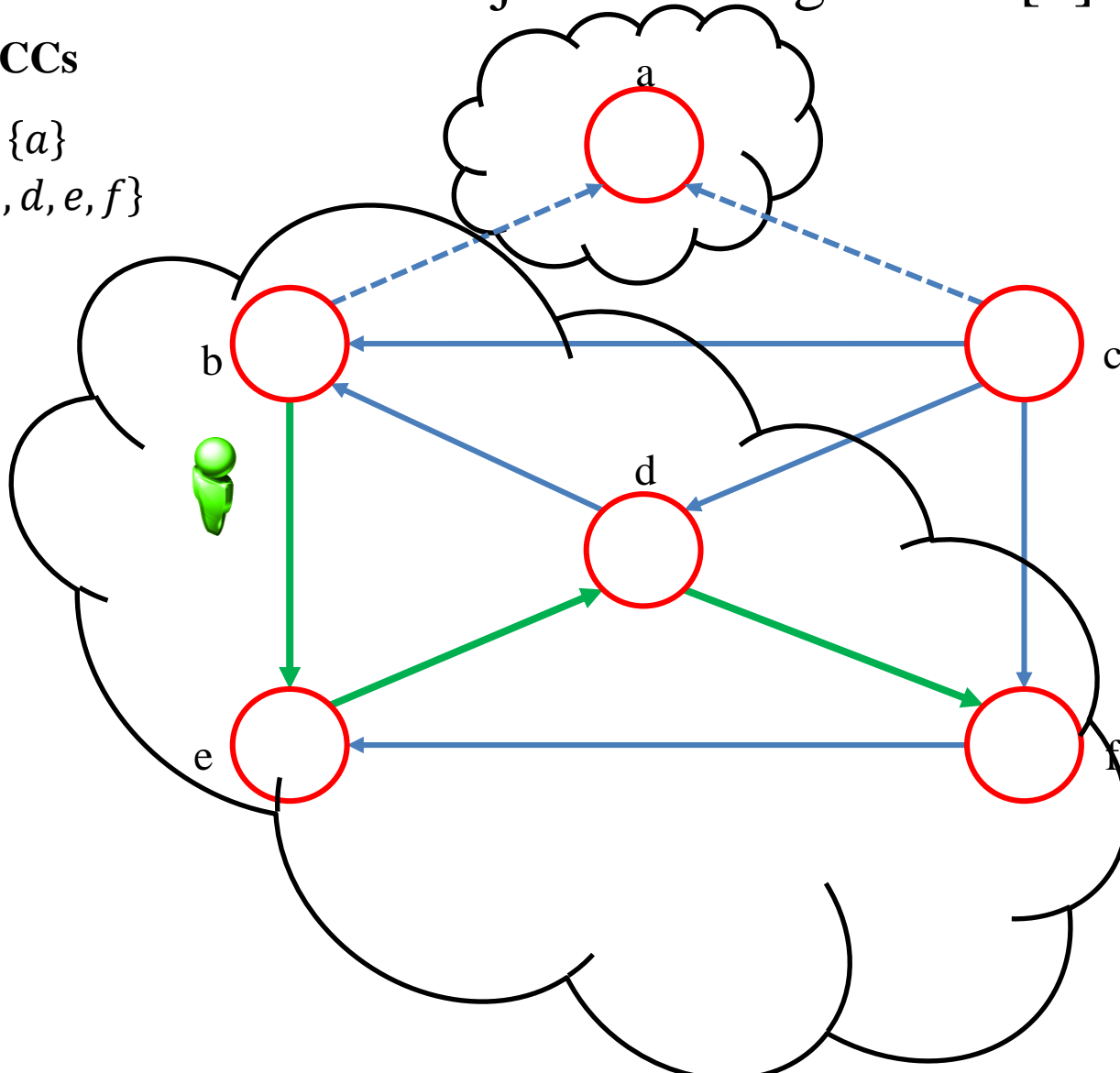

Kosaraju-Sharir algorithm [2]

SCCs

$\{a\}$
 $\{b, d, e, f\}$

$\{a, b, d, e, f, c\}$

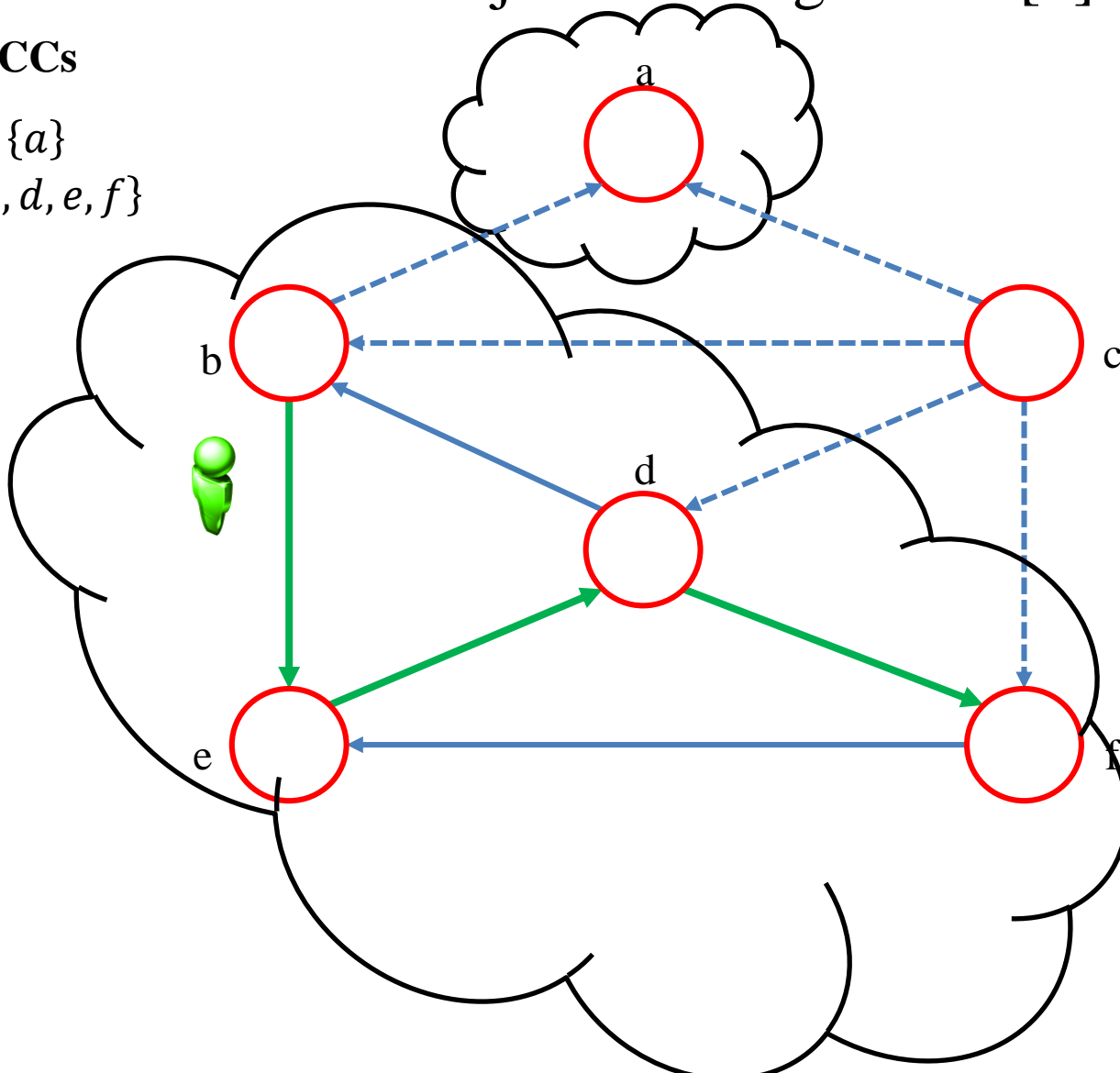

Kosaraju-Sharir algorithm [2]

SCCs

- $\{a\}$
- $\{b, d, e, f\}$
- $\{c\}$

$\{a, b, d, e, f, c\}$

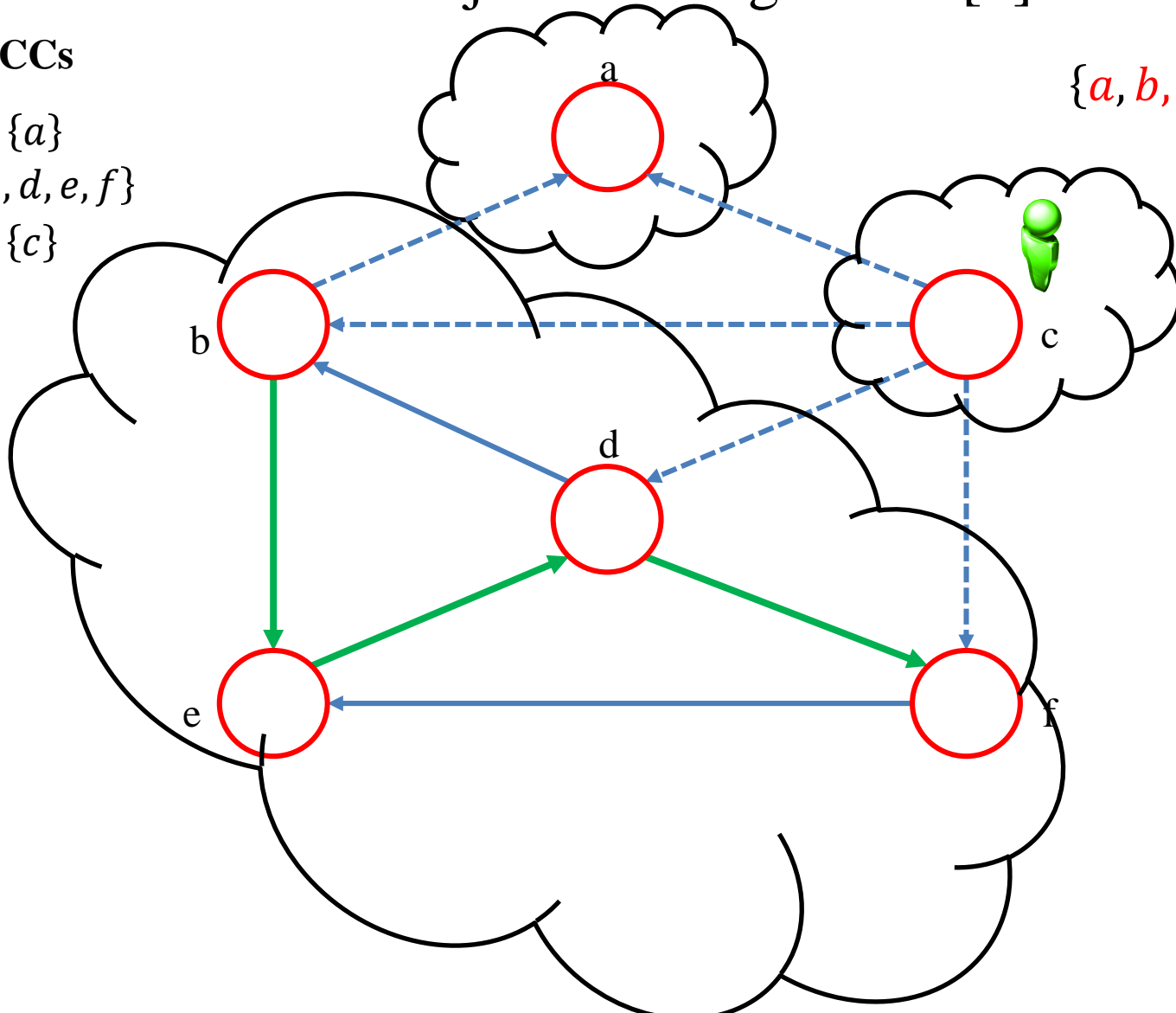

Complexity

$$O(E + V)$$